



DECEMBER

Conway Planning Commission

7:00pm • December 21, 2015 • 810 Parkway Avenue

CONWAY, ARKANSAS PLANNING COMMISSION MEETING AGENDA

7:00 pm • Monday • December 21, 2015
District Court Building • 810 Parkway

**SUBDIVISION COMMITTEE *WILL* MEET @ 6:30
in the UPSTAIRS conference room in City Hall**

Planning Commissioners

Lee Washington, Chairman
Mark Lewis, Vice-Chairman
Marilyn Armstrong
Justin Brown
Matthew Brown

Stan Hobbs
Bryan Quinn
Jerry Rye
Wendy Shirar
Anne Tucker

Contact the Planning Commission by email at planningcommission@cityofconway.org

Call to Order

Introduction & Chairperson Remarks

Minutes: November 16, 2015

1. **Subdivision and Replat**
 - A. Freeway Business Park, Phase IV Preliminary Subdivision
2. **Development Review Appeal**
 - A. Central Baptist Church Children's Education Building - Minimum Masonry Requirement Denial Appeal
3. **Annexation, Zoning and Conditional Use (Requires Public Hearing)**
 - A. Shaver Conditional Use Permit: MF-1 in R-2A
 - B. Last Chance Ministries Conditional Use Permit: Shelter for Homeless in RMH
4. **Discussion**
 - A. 2016 Planning Commission Nomination Schedule
 - B. 2016 Officer & Committee Assignments
 - C. 2016 Meeting & Deadline Schedule

Adjourn

Planning Staff Development Review/ Minor Subdivision Reports to the Planning Commission

The following items have been reviewed and approved by the Director of Planning and Development and are being reported to the Planning Commission as required by the Zoning and Subdivision Ordinances:

- A. **Development Reviews**
 - Chipotle, BK Dean PUD, 915 E Oak St
 - Tucker Creek Vet Clinic, 2725 College Ave
 - Conway Corp, New Office Building, 1307 Prairie St
- B. **Lot Splits, Lot Mergers, and Minor Subdivisions (filed for record)**
 - Conway Market Place East Replat Lot 2C; minor plat
 - Shaver Hayes Street Lot Merger; filed [L-266]
 - Pediatrics Plus Subdivision; filed [L-267]
 - Navistar Addition; filed [L-270]

The Conway Planning Commission makes recommendations to the City Council on public hearing items. The City Council will make a final decision on these items using the Planning Commission recommendations as a guide.

Items not approved by the Planning Commission may be appealed to the City Council within 30 days after Planning Commission denial. If an item is appealed to the City Council, a public notice sign will be placed on the property at least 7 days prior to the City Council meeting. A public notice will also be placed on the City's website: www.cityofconway.org.

Items reviewed at tonight's Planning Commission meeting may be considered by the City Council as early as January 12, 2016.

1A FREEWAY BUSINESS PARK, PHASE IV PRELIMINARY SUBDIVISION

FREeway BUSINESS PARK, PHASE IV PRELIMINARY SUBDIVISION

APPLICANT
 105 Development
 3200 W Tyler Street
 Conway, AR 72034

STAFF REVIEW BY
 Scott Grummer, City Planner
 1201 Oak Street
 Conway, AR 72032

SITE DATA
 Location. Property located at the intersection of S Harkrider Drive, Landmark Drive and Superior Drive.

Legal Description. On file

Site Area. 5.00 acres

Current Zoning. C-4 (Large Shopping Center Commercial District)

Existing Structures. None

Overlay. None

STAFF COMMENTS
 This subdivision divides the property to provide lots for commercial development along Interstate 40.

STAFF RECOMMENDATIONS
 Staff recommends approval of this subdivision subject to amended punch list. *The Planning Commission must consider Item 9.*

CONWAY CITY PLANNING DEPARTMENT REVIEW
FREeway BUSINESS PARK PHASE IV
PRELIMINARY PLAT
SUBMITTED BY
105 DEVELOPMENT
DECEMBER 10, 2015

This review lists the changes and/or additions as required by the Conway Subdivision Ordinance for preliminary plat approval.

- BASIC INFORMATION NEEDED ON THE PLAT**
1. If any portion of the land being subdivided is subject to flooding, the limit of such flooding shall be noted and the appropriate 100 year floodplain and/or floodway shall be identified.
 2. The present zoning classification of the adjoining land contiguous to the boundary of the proposed subdivision/replat is needed.
 3. The layout of all proposed sidewalk systems are needed, along with relevant dimensions and bearings.
 4. Proposed easements are needed. *Please place easement labels inside Easement Lines*

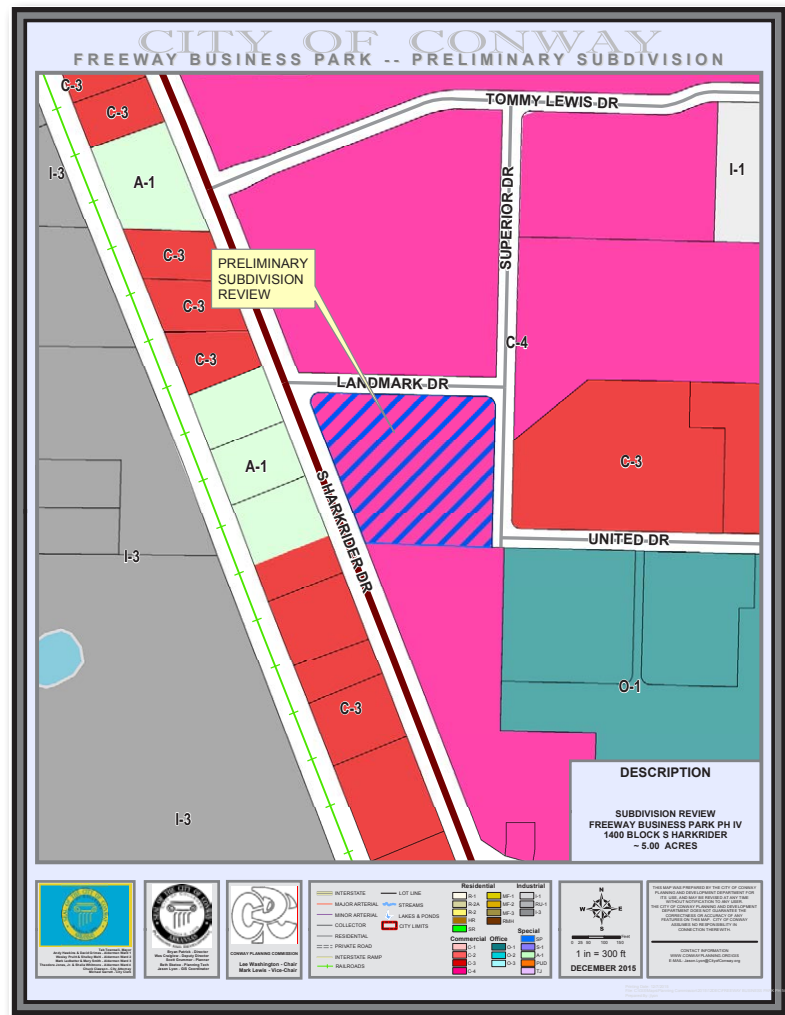

ADDITIONAL INFORMATION NEEDED, BUT NOT ON THE PLAT

5. Improvement plans for each new utility system are needed.
6. Improvement plans for any new drainage system, including location, size and construction of drainageways and structures and typical cross sections and centerline profiles are needed.
7. The Certificate of Preliminary Engineering Accuracy is needed on each set of street and drainage plans.
8. A draft of any Bill of Assurance proposed for the subdivision generally describing proposed covenants, restrictions and conditions applicable to the property included in the submitted plat is needed.

STREET DESIGN REQUIREMENTS

9. The rights-of-way of all streets must conform to the Master Street Plan and the requirements of Table 1, Street Classification & Design Standards, City of Conway in the Subdivision Ordinance. Additional right-of-way will not be required in the C-1 Central Business District where buildings would be in the right-of-way. ***A Variance has been received for reduced ROW width of United Drive from 60' as required by the Master Street Plan, to 50'. Planning Commission must approve this request or this condition must be corrected.***
10. The Planning Commission may authorize a new boundary street when the subdivider agrees to dedicate the entire right-of-way and construct all the required improvements.



EASEMENT DESIGN REQUIREMENTS

11. Utility easements as required by Conway Corporation are needed.
12. Drainage easements as required by the City Engineer are needed.

SIDEWALK DESIGN REQUIREMENTS

13. Sidewalks are required along both sides of all streets within all zoning districts within Conway city limits and within the Conway Territorial Jurisdiction. *Please correct Sidewalk Notes Street Names to match the plat.*
14. Sidewalks As Part of Commercial, Multi-Family, and Mixed Use Developments: Sidewalks along streets in commercial, multi-family, and mixed use subdivisions shall be constructed concurrently with building construction as part of site development review. Sidewalks shall be the responsibility of the builder/owner and not the developer. The sidewalk shall be installed prior to the final inspection and issuance of a certificate of occupancy. However, the developer of commercial subdivisions/replats with pre-existing development shall be required to meet the sidewalk provisions of Article 1101 Development Review of the Conway Zoning Ordinance.
15. When a developer creates a residential boundary street, the developer shall construct sidewalks along previously developed lots.

16. Any developer required sidewalk shall be constructed concurrently with other subdivision infrastructure. Such construction shall be completed or assurance for construction shall be required along with other infrastructure improvements prior to filing of the final plat.
17. All sidewalk construction location, and responsibility for construction shall be clearly identified on the final plat. Detailed sidewalk construction drawings coordinating sidewalks with other street/lot/easement infrastructure shall be shown on or included with the final plat.
18. Sidewalk elevation. The sidewalk elevation shall be two (2) percent above the top of the curb, sloping two percent towards the curb (one-fourth inch in each foot). This elevation shall be continuous through the driveway approach.
19. Driveway approach. The area remaining between the sidewalk and the flow-line of the gutter, called the approach to the driveway, shall slope up to the elevation of the sidewalk.
20. Sidewalks shall link sidewalks of adjoining lots so as to provide a continuous "ribbon" of pedestrian access throughout the community.

FEE REQUIREMENTS

21. Appropriate fees must be paid.

Punch List cont.

OTHER REQUIREMENTS
 22. In addition to the requirements established herein, all subdivision plats shall comply with all other applicable rules, regulations and laws including but not limited to the Growth Plan (Comprehensive Plan), the Conway Zoning Ordinance, building and housing codes, and any other regulations adopted by the City Council and any regulations or special requirements of the State Health Department, State Highway & Transportation Department, or other appropriate State agencies.

AUTHORIZATION TO PROCEED
 23. Receipt of an approved or conditionally approved copy of the Preliminary Plat, together with an approved copy of the Improvements Plan shall constitute authorization of the Planning Commission for the developer to proceed with the preparation of the Final Plat, the installation of improvements, and the staking out of lots and blocks. The developer, after conditional approval of the Preliminary Plat, shall complete all improvements required under this regulation.

EXPIRATION OF PLAT
 24. Plats will expire at the end of one year from the acceptance of the Preliminary Plat unless an extension is requested and granted by the Planning Commission. The Freeway Business Park Phase IV will expire on December 4, 2016.

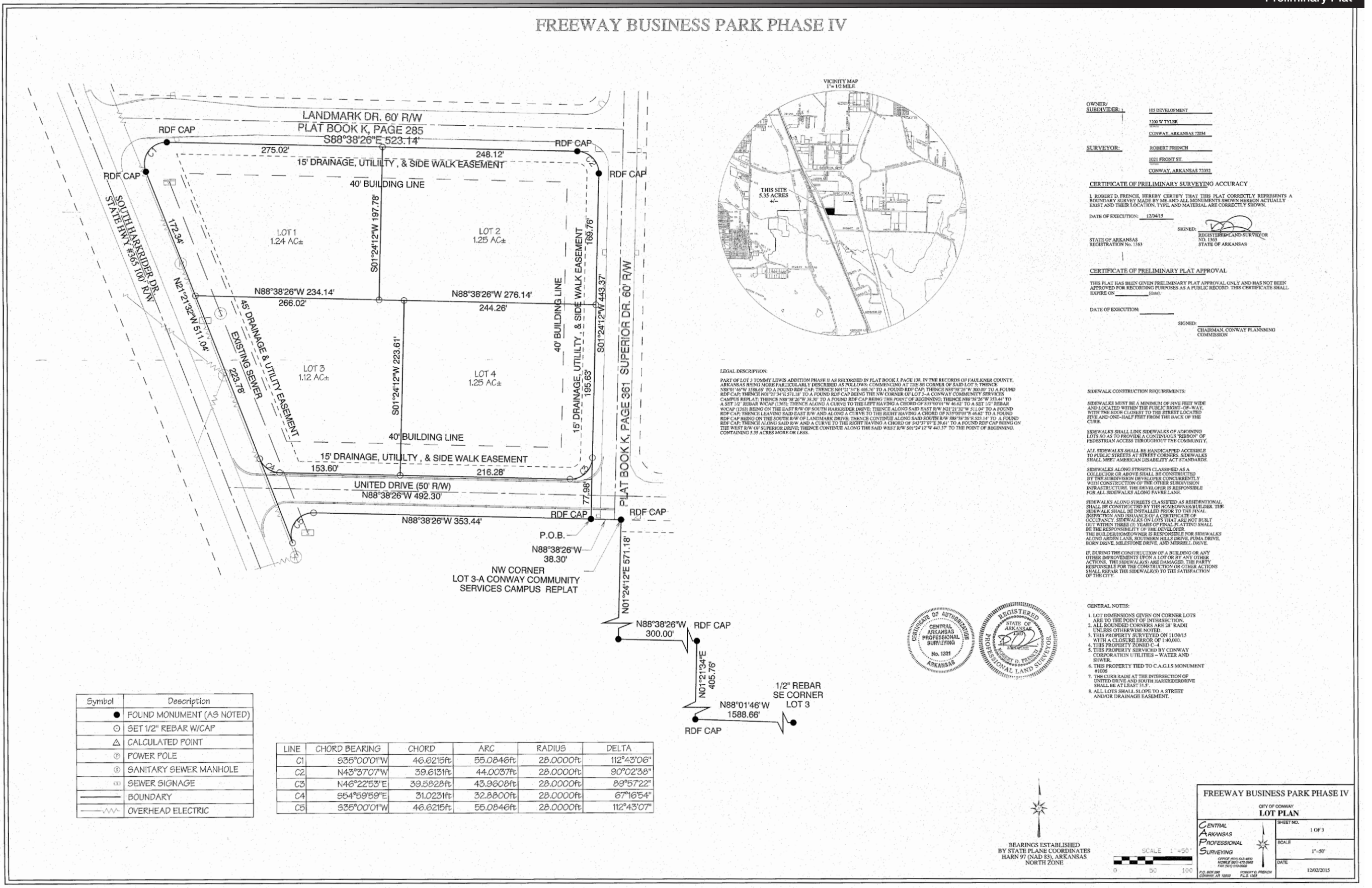

OWNER/SUBDIVIDER:
 103 DEVELOPMENT
 1300 W TYLER
 CONWAY, ARKANSAS 72024

SURVEYOR:
 ROBERT D. FRENCH
 1021 FRONT ST.
 CONWAY, ARKANSAS 72024

CERTIFICATE OF PRELIMINARY SURVEYING ACCURACY
 I, ROBERT D. FRENCH, HEREBY CERTIFY THAT THIS PLAT CORRECTLY REPRESENTS A BOUNDARY SURVEY MADE BY ME AND ALL MONUMENTS SHOWN HEREON ACTUALLY EXIST AND THEIR LOCATION, TYPE AND MATERIAL ARE CORRECTLY SHOWN.
 DATE OF EXECUTION: 12/04/15
 SIGNED: REGISTERED LAND SURVEYOR NO. 11633 STATE OF ARKANSAS

CERTIFICATE OF PRELIMINARY PLAT APPROVAL
 THIS PLAT HAS BEEN GIVEN PRELIMINARY PLAT APPROVAL ONLY AND HAS NOT BEEN APPROVED FOR RECORDING PURPOSES AS A PUBLIC RECORD. THIS CERTIFICATE SHALL EXPIRE ON: _____
 DATE OF EXECUTION: _____
 SIGNED: CHADMAN, CONWAY PLANNING COMMISSION

Symbol	Description
●	FOUND MONUMENT (AS NOTED)
○	SET 1/2" REBAR W/CAP
△	CALCULATED POINT
Ⓧ	POWER POLE
Ⓞ	SANITARY SEWER MANHOLE
Ⓜ	SEWER SIGNAGE
—	BOUNDARY
—	OVERHEAD ELECTRIC

LINE	CHORD BEARING	CHORD	ARC	RADIUS	DELTA
C1	S35°00'01"W	46.6215ft	55.0846ft	28.0000ft	112°43'06"
C2	N43°37'07"W	39.6131ft	44.0037ft	28.0000ft	90°02'38"
C3	N46°22'53"E	39.5928ft	43.9608ft	28.0000ft	89°57'22"
C4	S54°59'59"E	31.0231ft	32.8800ft	28.0000ft	67°16'54"
C5	S35°00'01"W	46.6215ft	55.0846ft	28.0000ft	112°43'07"



GENERAL NOTES:
 1. LOT DIMENSIONS GIVEN ON CORNER LOTS ARE TO THE POINT OF INTERSECTION.
 2. ALL ROUNDED CORNERS ARE 28' RADII UNLESS OTHERWISE NOTED.
 3. THIS PROPERTY SURVEYED ON 11/20/15 WITH A CLOSURE ERROR OF 1:40,000.
 4. THIS PROPERTY ZONED C-4.
 5. THIS PROPERTY SERVICED BY CONWAY CORPORATION UTILITIES - WATER AND SEWER.
 6. THIS PROPERTY TIED TO C.A.G.I.S. MONUMENT #106.
 7. THE CURB RADIUS AT THE INTERSECTION OF UNITED DRIVE AND SOUTH HARBINGER DRIVE SHALL BE AT LEAST 11.5'.
 8. ALL LOTS SHALL SLOPE TO A STREET AND/OR DRAINAGE EASEMENT.

FREEWAY BUSINESS PARK PHASE IV LOT PLAN
 SHEET NO. 1 OF 3
 SCALE 1" = 50'
 DATE 12/02/2015

BEARINGS ESTABLISHED BY STATE PLANE COORDINATES HARN 97 (NAD 83), ARKANSAS NORTH ZONE

SCALE 1" = 50'

0 50 100

2A CENTRAL BAPTIST CHURCH DEVELOPMENT REVIEW DENIAL APPEAL

CENTRAL BAPTIST CHURCH DEVELOPMENT REVIEW DENIAL APPEAL

APPLICANT

Barry Hoffman
Hoffman Architectural
102 N. Spring Street
Searcy, AR 72143

OWNER

Central Baptist Church
3333 Dave Ward Drive
Conway, AR 72034

STAFF REVIEW BY

Wes Craiglow, Deputy Director of Development
1201 Oak Street
Conway, AR 72032

SITE DATA

Location. 3333 Dave Ward Drive

Legal Description. On file

Site Area. 12.82 acres

Current Zoning. A-1 (Agricultural).

Existing Structures. One, 54,590 sf worship facility

Overlay. None

Requested Variance. Exception to the design standard governing minimum required percentage of masonry on building façade.

STAFF COMMENTS

The Planning Dept does not support the complete elimination of the city's façade design standards. There is neither precedence for that action nor would it, in any way, meet the spirit and intent of the building ordinance. The Planning Dept staff recognizes that the City Council has been clear and consistent on the enforcement of the city's 50% masonry standard as required by Section 1101.7.C.3.a.ii of the Conway Zoning Ordinance O-94-54, which states *"Masonry shall occupy no less than 51% of any façade of any structure."*

However, in this case, the Planning Department considers a compromise of those standards as a better design choice, due to the pre-existing, non-conforming structure on the site today. This compromise can be justified using Section 1101.7.C.1 of the Conway Zoning Ordinance, O-94-54, which encourages all structures on a site to have a unified design theme. Though the existing structure's façade is non-conforming to current design requirements, the use of canopy trees to screen the large expanse of metal panels and break up the overall mass of the large structure is helpful.

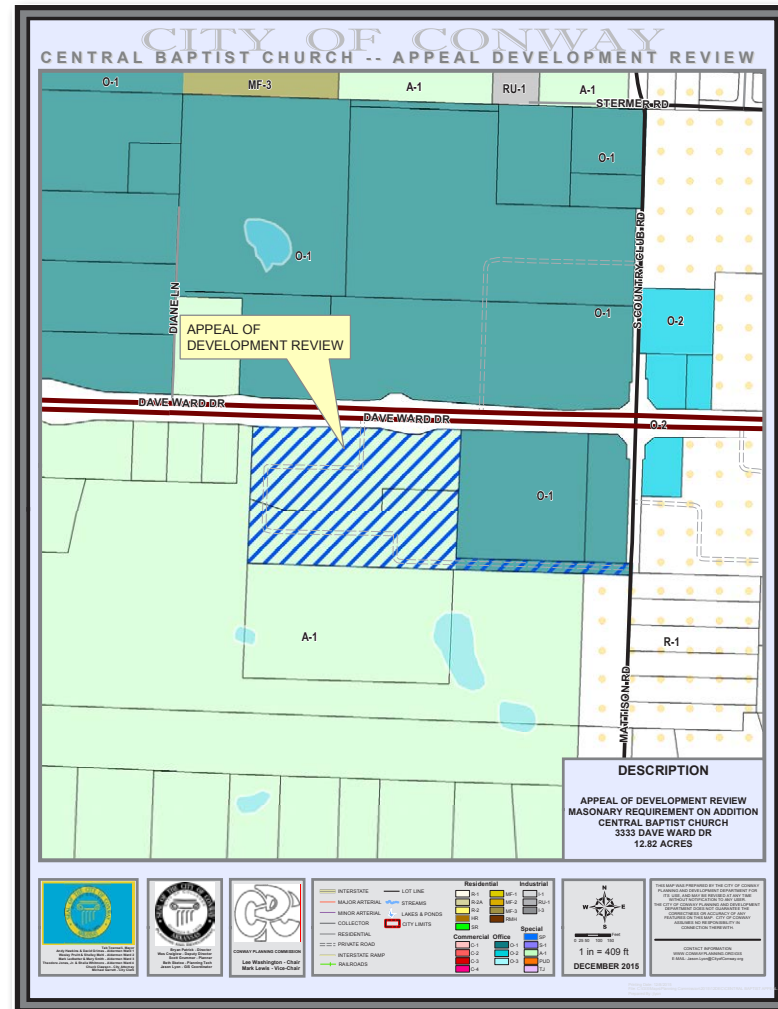

Although the Planning Department has empathy for the financial constraints of every project—especially those of non-profit organization such as religious institutions and public schools—it should be noted that in every other case which has come before the Planning Department staff since 2007, the standards have been enforced equitably and consistently on all projects.

STAFF RECOMMENDATIONS

Staff recommends that the façade of the addition should match the façade of the existing structure in both color and material, by type and wall area and therefore a variance be granted per suggested conditions below.

SUGGESTED CONDITIONS

1. The proposed addition to match those existing design features in color and type, to a reasonable level of +/- 10% of wall area.
2. Tree planting along eastern side of building immediately adjacent to the wall, irrespective of the amount of brick installed.

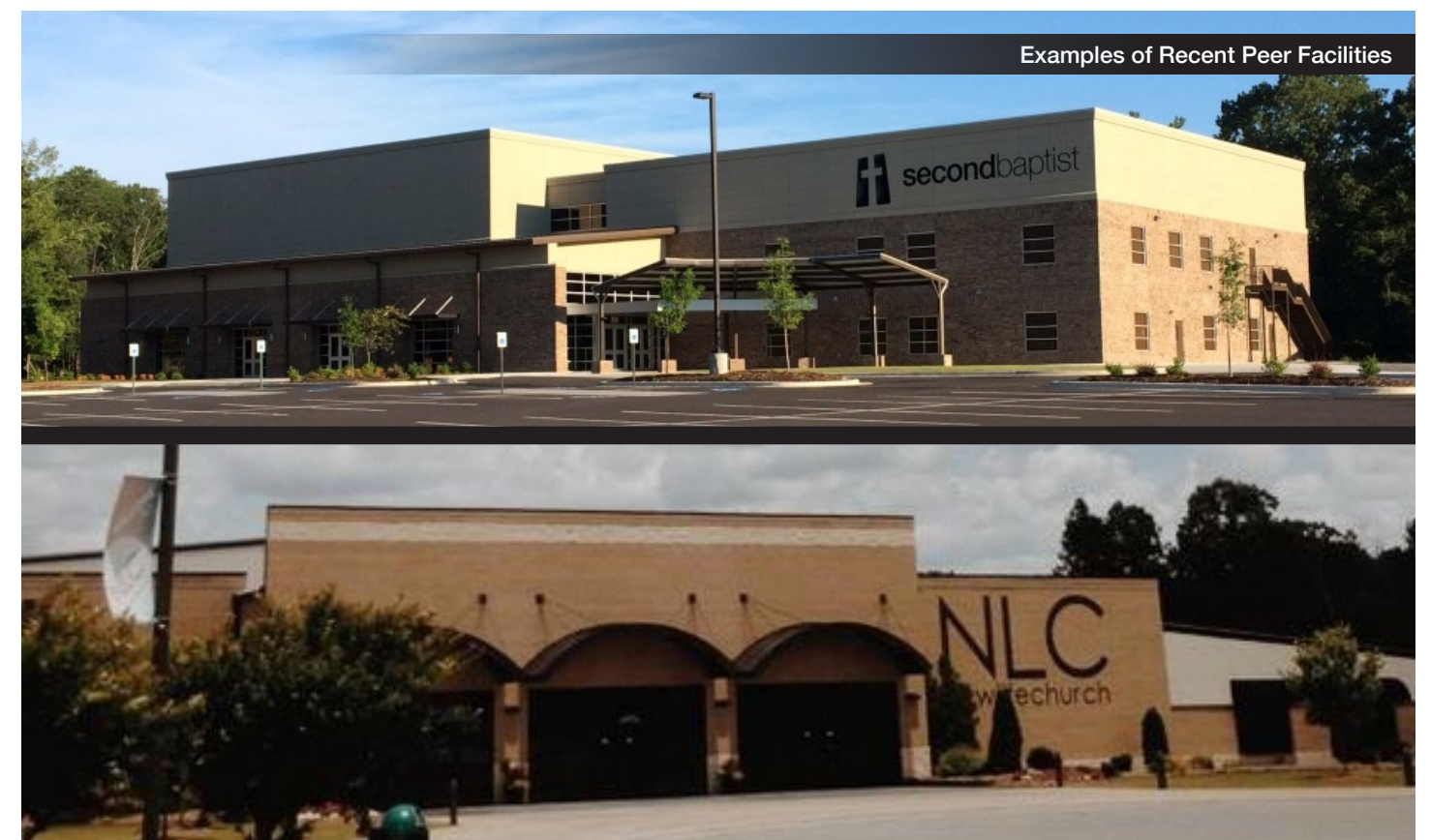

FORM: DR-05



PLANNING DEPARTMENT

City of Conway

1201 OAK STREET CONWAY, AR 72032 (501) 450-6105

development review notice of appeal

Date: 11.24.2015

Development Name: CENTRAL BAPTIST CHURCH (ADDITION)

Representing Party and Title: BARRY HOFFMAN (ARCHITECT)

Development Address: 3333 DAVE WARD DRIVE Subdivision: N/A

Zoning Class: A1+01 Lot/Parcel #: N/A Geolocator (T/R,SECT,1/4): 051415 SW (CUP #s: 1139 & 1161)

Appellate To (check one):

Conway Planning Commission

Conway City Council

Please be advised that an appeal is hereby taken to the City of Conway, Arkansas for the action of the Planning Director in refusing to issue a Development Review Approval in accordance with Article 1101 of the City of Conway Zoning Ordinance (O-94-54). The disputed Section, Paragraph, and/or Subparagraph (Article 1101) is indicated below:

SEE ATTACHED SHEET

By signing below, I understand that the appellate board which is to consider this appeal shall hear, review, and decide upon only the above listed grievances specifically.

DATE: 11/10/15

PROJECT LOCATION

ADDRESS: 3333 DAVE WARD DRIVE

SUBDIVISION:

BLOCK: LOT:

DESCRIPTION OF VARIANCE BEING SOUGHT (attach any necessary drawings):

A VARIANCE FROM THE 1101.7 DEVELOPMENT STANDARD FOR EXTERIOR CONSTRUCTION MATERIALS TO ALLOW FOR A REDUCTION IN THE REQUIRED PERCENTAGE OF MASONRY AT THE PROJECTS EAST FACADE IN ORDER TO BE MORE COHESIVE WITH THE EXISTING STRUCTURE TO WHICH THE PROJECT WILL CONNECT.

PROPOSED USE: CHURCH CHILDREN'S EDUCATION BUILDING

APPLICANT'S NAME: BARRY HOFFMANN PHONE NUMBER: 501-268-4743

APPLICANT'S EMAIL ADDRESS: Barry@HoffmannArchitectural.com

APPLICANT'S ADDRESS: 102 N. SPRING STREET SEARCY AR 72143

APPLICANT'S SIGNATURE: [Handwritten Signature]

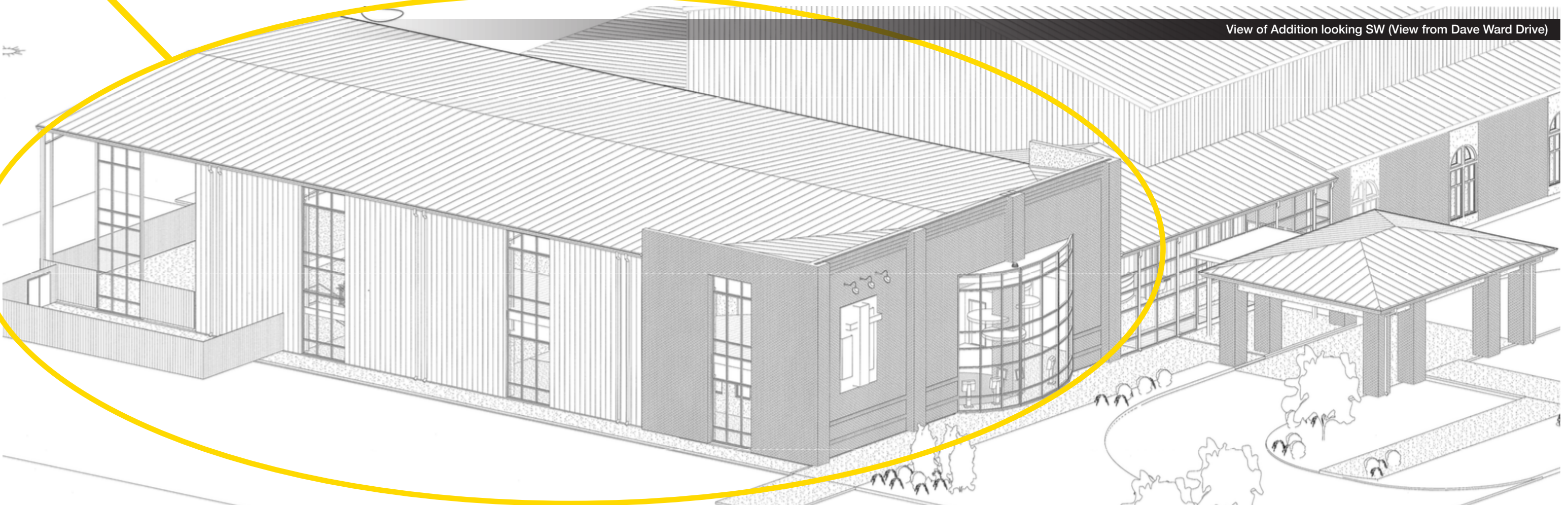
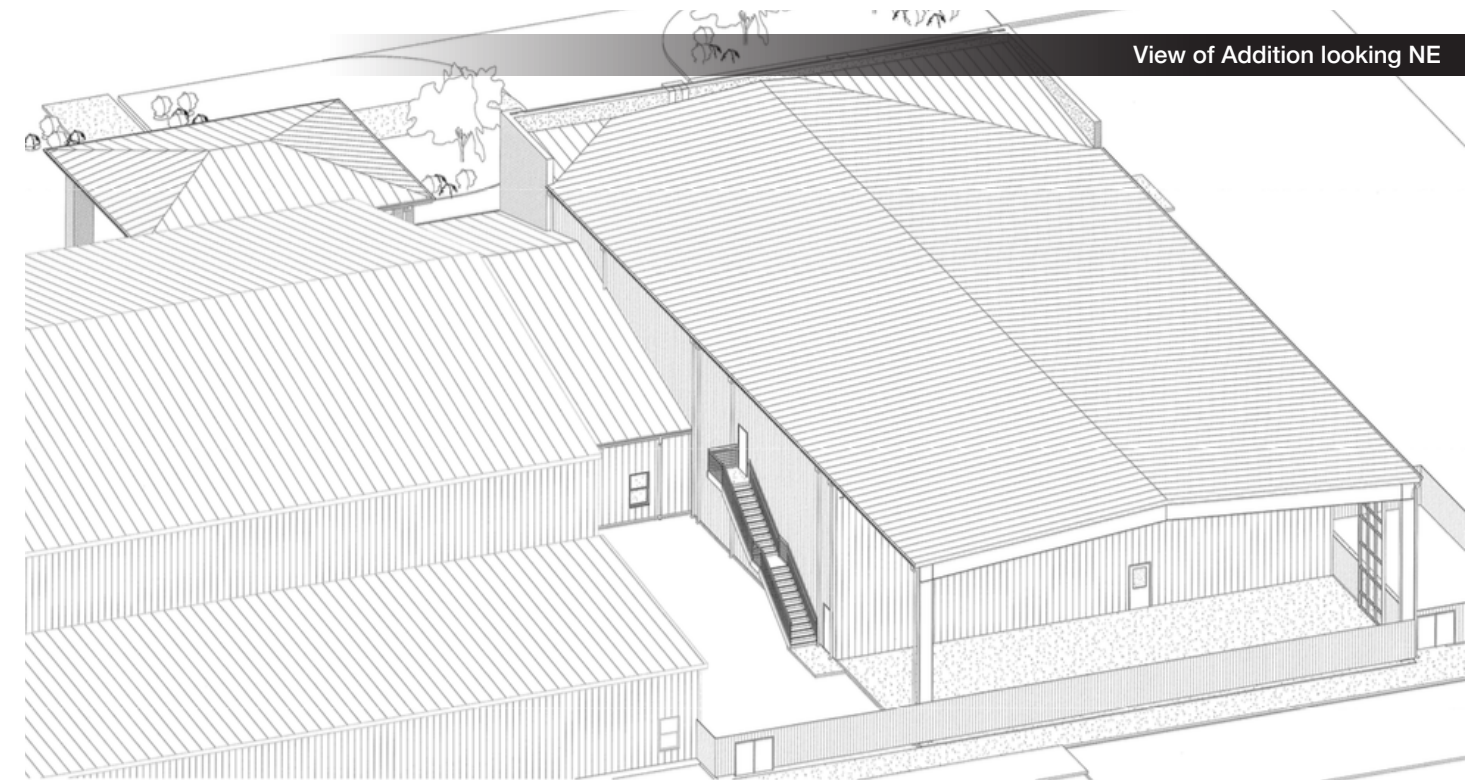

3A SHAVER PROPERTIES CONDITIONAL USE PERMIT REQUEST

SHAVER PROPERTIES CONDITIONAL USE PERMIT REQUEST TO ALLOW MF-1 DENSITY IN R-2A (LARGE LOT DUPLEX)

APPLICANT
 Allen Shaver
 1261 Harkrider Street
 Conway, AR 72032

STAFF REVIEW BY
 Bryan Patrick, Director of Planning
 1201 Oak Street
 Conway, AR 72032

SITE DATA
 Location. 1919 and 1921 Clifton Street

Site Area. 2.4 acres +/-

Existing Structures. A 1652 square foot home (1919 Clifton) and a 1288 square foot home (1921 Clifton) and accessory buildings

Current Zoning. R-2A (Large Lot Duplex)

Requested Rezoning. To allow MF-1 (Multifamily 1 density - 12 units per acre)

Overlay District. None

Comprehensive Plan. The Comprehensive Plan shows this property as appropriate for single family residential. However, the property is zoned R-2A (Large Lot Duplex)

Projected Traffic Impact. Under current R-2A zoning, the two residences generate around 20 vehicle trips per day. If the property were given MF-1 density, 28 units could be constructed generating approximately 280 vehicle trips per day.

Utility Infrastructure. Conway Corporation Engineering will review and consider the adequacy of existing infrastructure. Extensions and re-routing of utilities may be required. Easements will likely be required to provide for future area development.

Flood/Drainage. No part of the requested property is within any flood plain or flood way. However, the area is level and there are local drainage problems. Any new development will need oversight by City Engineering to ensure that adequate drainage is provided by the development.

Street Improvements. No street improvements are planned for Clifton Street in the near future.

Conway 2025. Not directly applicable

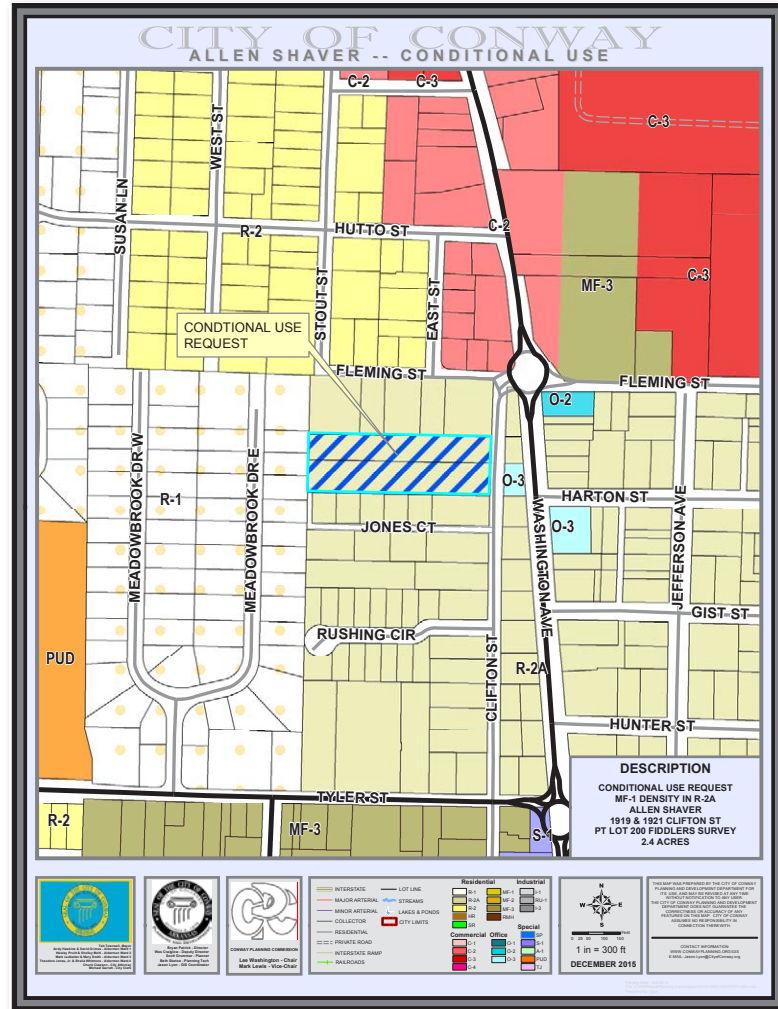

STAFF COMMENTS

The applicant is requesting a conditional use permit to increase the density of two large deep parcels. The two parcels are approximately 80' x 570' and 100' x 570'. Currently, there are two single family residences on the two lots. Without a conditional use permit or multi-family zoning, the lots are limited to 1 single family residence and 1 duplex or 3 units total.

With a conditional use for MF-1 density, 28 units could be constructed. The applicant incorrectly noted 33 units possible on submitted documents. The proposal would keep the existing single family homes fronting Clifton Street and construct a 20 foot private drive serving a mix of single family and duplex structures. A fire code approved turn-around would be constructed towards the western end of the property.

STAFF RECOMMENDATIONS

Planning Staff recommend the approval of this request if appropriate conditions can be crafted to ensure compatibility with the surrounding area.

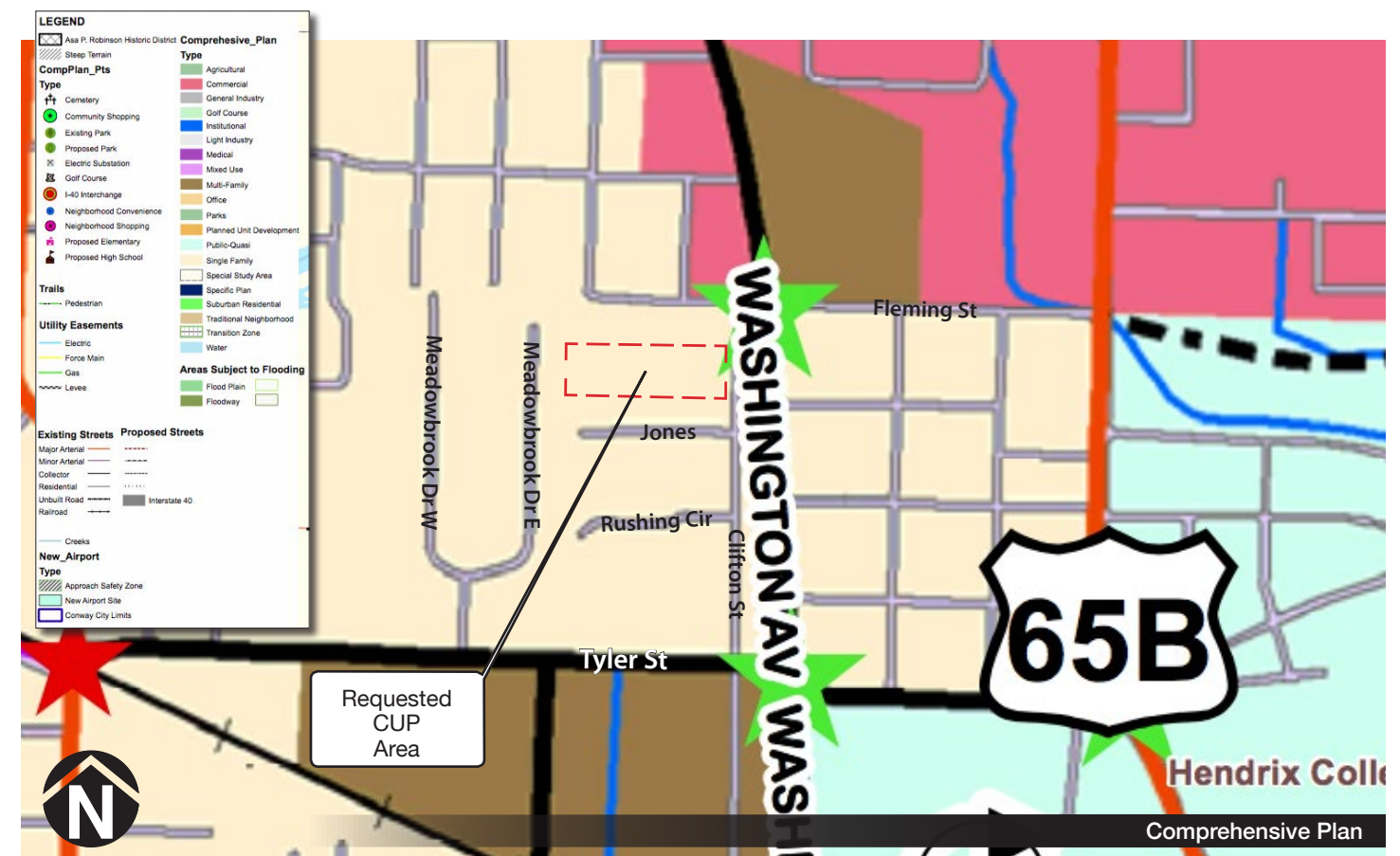

Suggested Conditions on p.18

3A SHAVER PROPERTIES CONDITIONAL USE PERMIT REQUEST

STAFF CONDITIONS

The following list of conditions is not complete and should be considered a "starting point" for conditions. The Commission should take public comment and revise, add to, or delete from the suggested conditions appropriately.

The following conditions are recommended:

1. Planning Department development review is required. Particularly, drainage approval by the City Engineering Department.
2. Platting of the property is required. Platting will include additional street right of way as required.
3. The development is limited to a maximum of 28 units.
4. A 6 foot privacy fence is required along the south property line.
5. A 20 foot wide (or Fire Department approved width) private drive with approved fire apparatus turn-around will serve the development. The City will not maintain the private drive. On street parking is not allowed.
6. Setbacks as shown on the submitted site plan shall be allowed.
7. Sidewalks are required on both sides of the private street. Due to reduced setbacks, the sidewalk may be placed at back of curb.

Applicant Provided Sketch - Proposed Site Plan

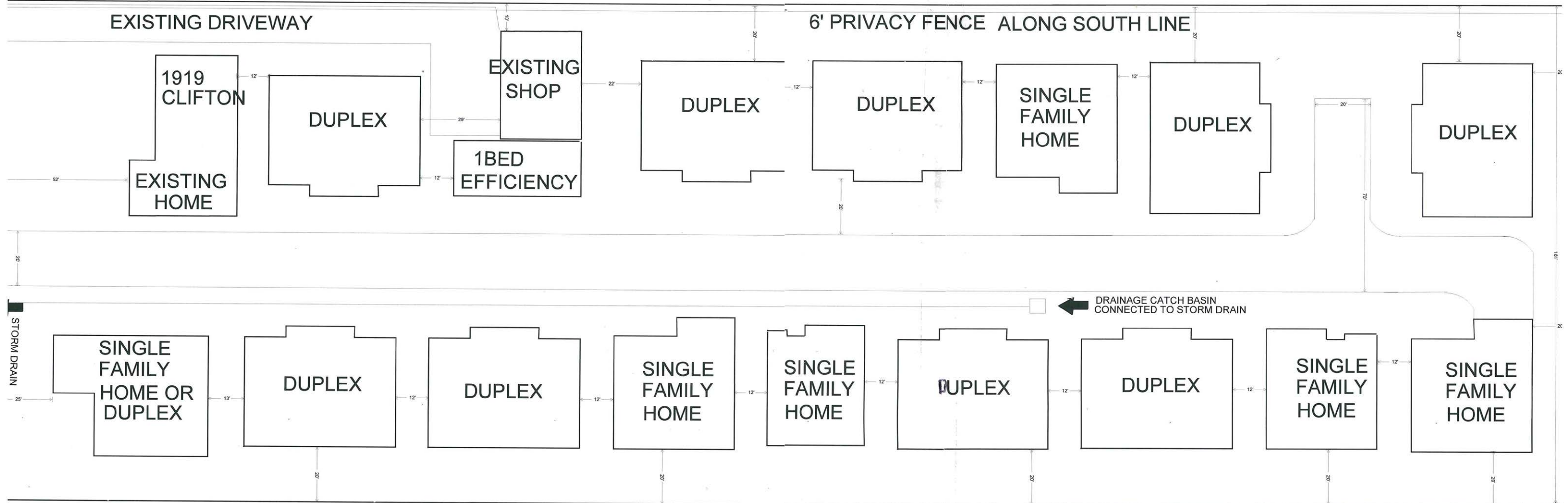

06247 SQ FT .44 ACRES 33 UNITS POSSIBLE MAX WITH CONDITIONAL USE WE ARE ASKING FOR 28 MAX

3B LAST CHANCE MINISTRIES/MEEKS CONDITIONAL USE PERMIT REQUEST

LAST CHANCE MINISTRIES/MEEKS CONDITIONAL USE PERMIT REQUEST TO ALLOW A HOMELESS SHELTER IN RMH (MOBILE HOME DISTRICT)

APPLICANT
 Patricia Meeks
 Last Chance Ministries
 3 Brown St
 Conway, AR 72032

STAFF REVIEW BY
 Bryan Patrick, Director of Planning
 1201 Oak Street
 Conway, AR 72032

SITE DATA
 Location. 450 East Robins Street House 21 and surrounding property.

Site Area. .55 acres +/-

Existing Structures. A 1000 +/- square foot home and several accessory buildings

Current Zoning. RMH (Mobile Home District)

Requested Conditional Use Permit. To allow a homeless shelter.

Overlay District. None

Comprehensive Plan. The Comprehensive Plan shows this property as appropriate for multi-family. However, the property is currently within a mobile home park.

Projected Traffic Impact. With the current RMH zoning and 1000 square foot residence, around 10 vehicle trips per day could be expected. If the property were used as a homeless shelter, an increase in vehicle trip generation could be expected with employees, deliveries, and guests transportation. However, a projected amount of vehicle trip generation is difficult to determine without the number of guests, employees, etc.

Flood/Drainage. No part of the requested property is within any flood plain or flood way.

Street Improvements. No street improvements are planned for Robins Street in the immediate future. The old airport is expected to be redeveloped into a shopping center in the next 2-5 years. Robins is expected to connect to a future north-south connector running between Bruce and Commerce. The north-south connector and Robins improvements are expected to happen during a later phase of the shopping center development.

Conway 2025. Not directly applicable

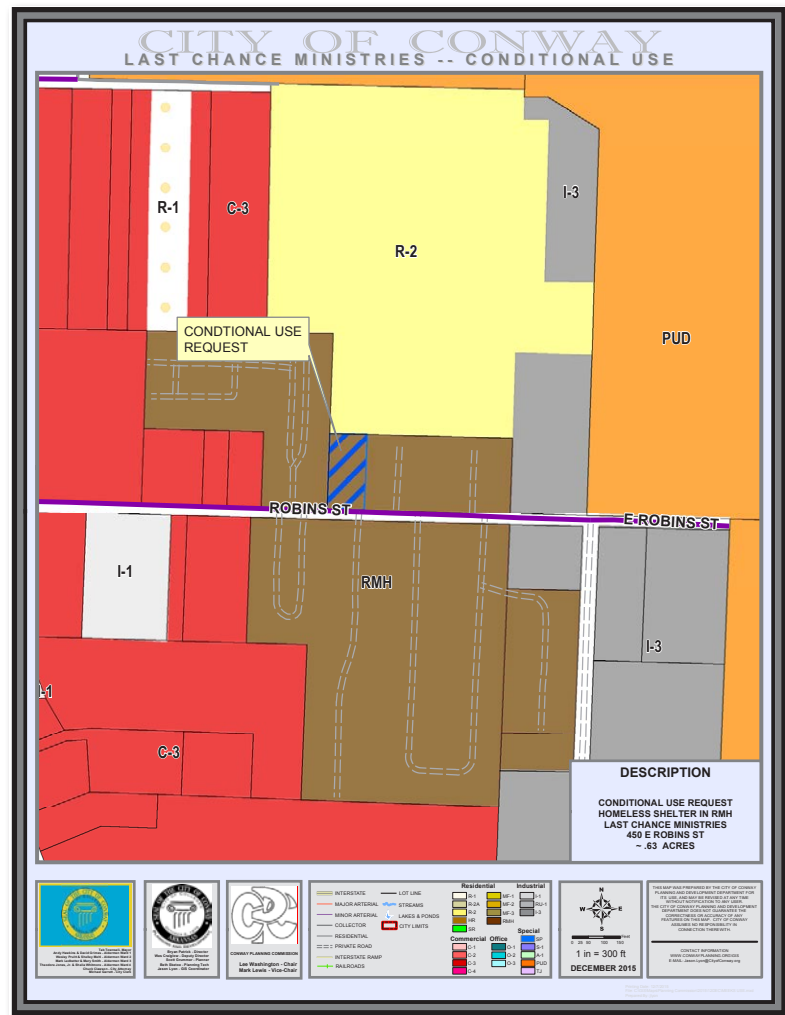

STAFF COMMENTS

The applicant is requesting a conditional use permit to operate a homeless shelter.

The submitted applicant states, "We provide shelter for those who literally are sleeping outside and for those who are elderly and displaced, sick, blind, in crisis, of medical issues and mental issues that have been dropped off in streets. We are here for those nobody wants to help. To get them into responsible stable places so they don't resort to stealing and breaking the law."

It would appear that the applicant has been operating a homeless shelter at this location for some time. Aside from housing guests in the house, there are several small accessory buildings that are being used for housing. None of these structures meet fire code for group housing.

STAFF RECOMMENDATIONS

The applicant has not submitted information to describe current management, number of occupants, number of employees, or desired future operation. The Planning Commission will need to ascertain necessary information from the applicant and take public comments in order to reach a decision and possibly create applicable conditions.

Recommendations cont.

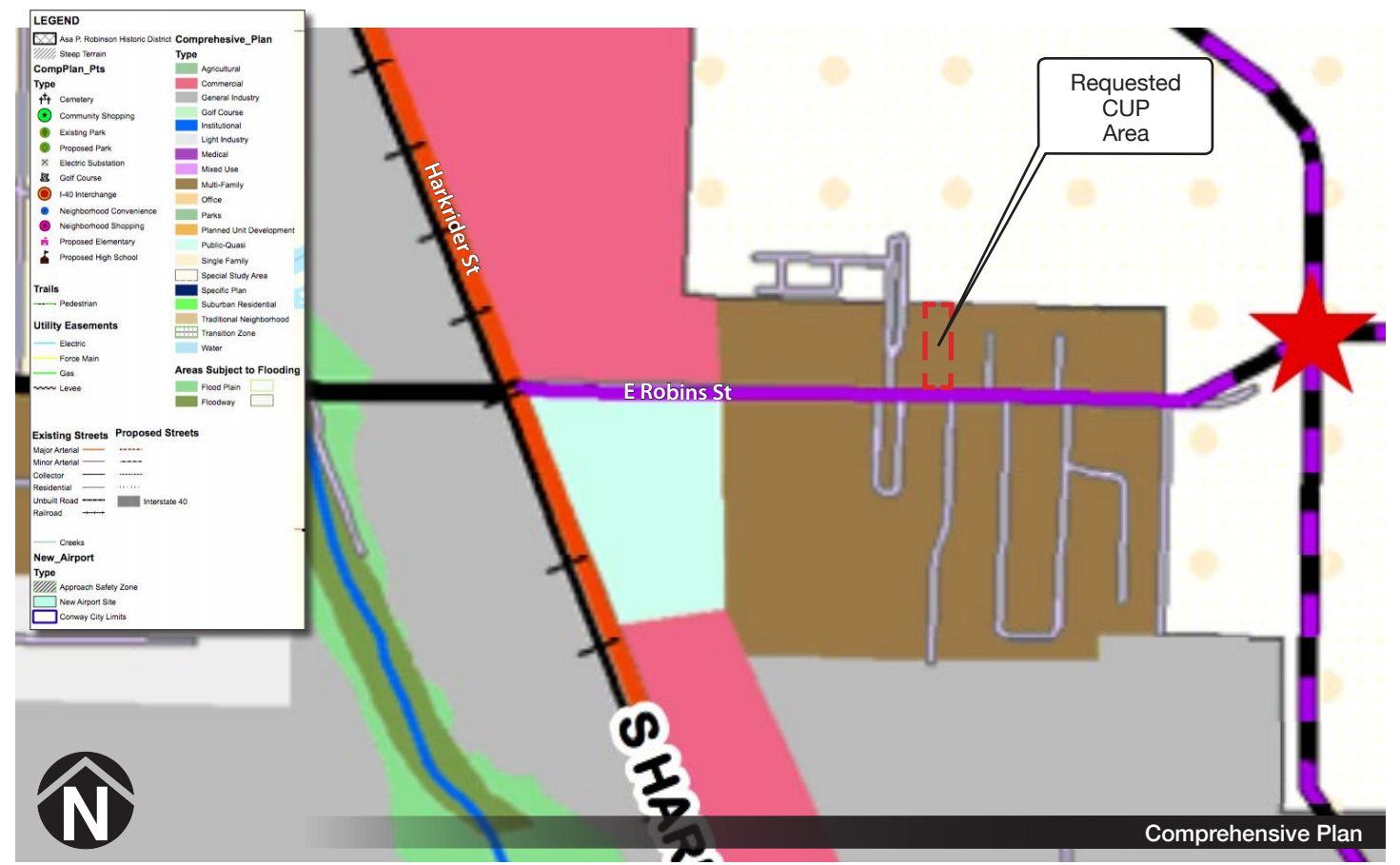
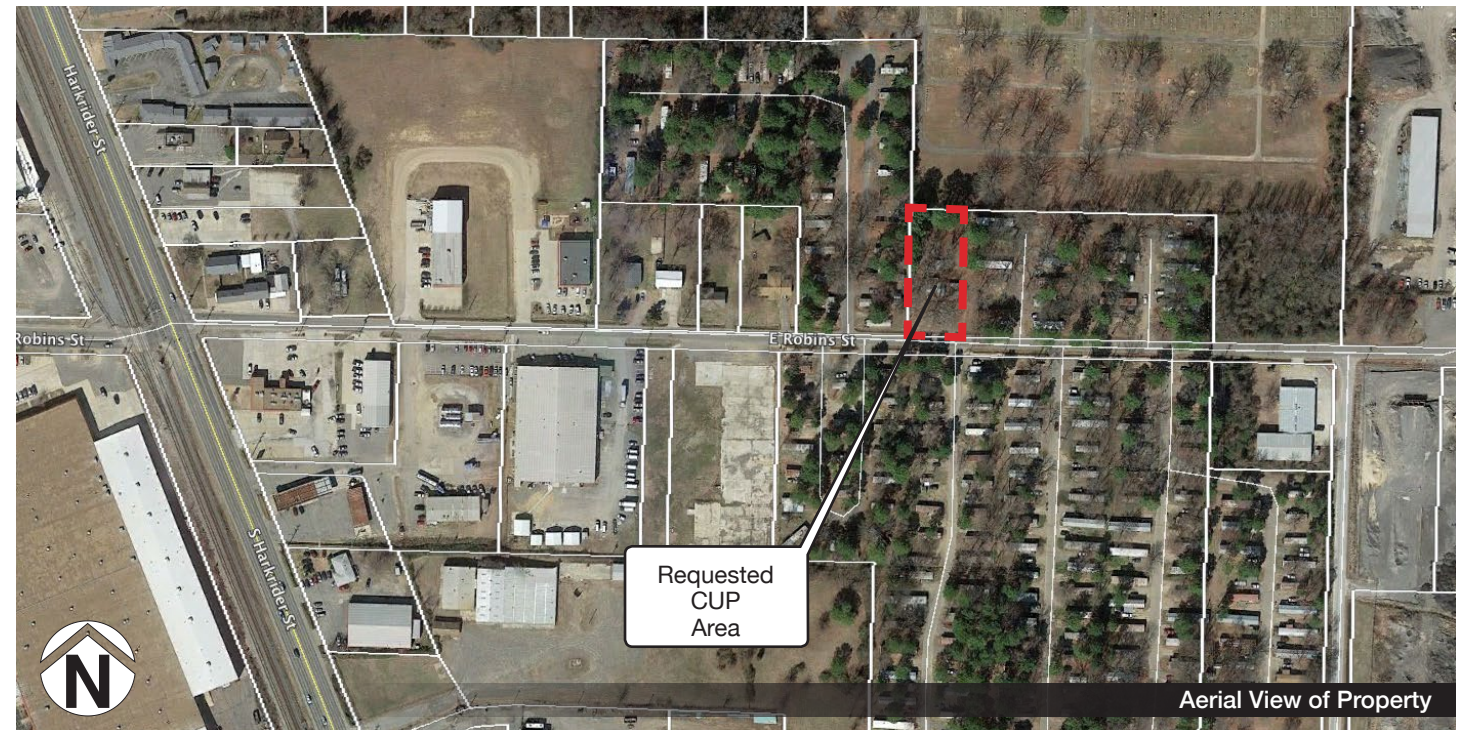

A previous homeless shelter request generated concerns for:

- Fire and life safety standards
- 24/7 Supervision
- Video surveillance
- Allowable occupants (no sex offenders)
- Maximum number of occupants
- State ID requirement
- Background checks

4A 2016 PLANNING COMMISSION NOMINATION SCHEDULE

Due to an oversight, five eligible nominees were not considered during the selection process. As a result, the approval of selected nominees was held in committee by the City Council at their December 8th meeting. Interviews were planned for Tuesday, December 15th, for those of these additional five nominees selected. Following these interviews, the Planning Commission will need to discuss and vote whether to maintain the previously selected nominees or make changes to their selections. Depending on the timing of this vote, the final selections of nominees will be sent to the City Council either on December 22nd, 2015 or January 12th, 2016. If the later, it will be a very short notification window for the new commissioners as the first Planning Commission meeting of 2016 is Tuesday, January 19th.

Two new members will be needed in 2016 to fill Lee Washington's and Anne Tucker's positions. Anne Tucker has opted to step in and complete Stan Hobbs' term, which ends in 2017. The two new 5 year terms will expire in 2020.

City wide representation is a desirable trait of the Planning Commission. Not including the Lee Washington or Stan Hobbs and accounting for Mark Lewis' recent move, the Planning Commission consists of:

- Ward 1: 2 members
- Ward 2: 1 member
- Ward 3: 3 member
- Ward 4: 2 members

Lee Washington resides in Ward 3 and Stan Hobbs in Ward 2.

Ideally, the new members would represent a combination of Wards 1, 2 and 4.

4B 2016 OFFICER & COMMITTEE ASSIGNMENTS

2016 OFFICERS		
CHAIRMAN	VICE-CHAIRMAN	SECRETARY

2015 COMMITTEES			
ANNEXATION	CONDITIONAL USE	SUBDIVISION	ZONING
Marilyn Armstrong	Marilyn Armstrong	Matthew Brown*	Marilyn Armstrong*
Justin Brown	Justin Brown	Bryan Quinn	Bryan Quinn
Mark Lewis	Mark Lewis*	Jerry Rye	Jerry Rye
Anne Tucker*	Anne Tucker	Wendy Shirar	Wendy Shirar
Vacant	Vacant	Vacant	Vacant

2016 COMMITTEES			
ANNEXATION	CONDITIONAL USE	SUBDIVISION	ZONING

*indicates Chairman

4C 2016 MEETING & DEADLINE SCHEDULE

2016 CONWAY PLANNING COMMISSION SCHEDULED MEETING DATES

<u>MONTH</u>	<u>MEETING DATE</u>	<u>SUBMISSION DEADLINE</u>
January	Tuesday, January 19 ¹	Monday, January 4
February	Tuesday, February 16 ²	Friday, January 29
March	Monday, March 21	Friday, March 4
April	Monday, April 18	Friday, April 1
May	Monday, May 16	Thursday, April 28
June	Monday, June 20	Friday, June 3
July	Monday, July 18	Friday, July 1
August	Monday, August 15	Friday, July 29
September	Monday, September 19	Friday, September 2
October	Monday, October 17	Friday, September 30
November	Monday, November 21	Friday, November 4
December	Monday, December 19	Friday, December 2

Conway Planning Commission meetings begin at 7:00 pm in the Russell L. "Jack" Roberts District Court Building located at 810 Parkway Avenue, Conway, Arkansas. The agenda with supporting information for each meeting is available at <http://www.cityofconway.org/pages/planning-minutes-reports/>

¹Meeting moved due to Martin Luther King, Jr. Day Observance

² Meeting moved due to Presidents' Day Observance

See you in

