



CITY OF CONWAY, ARKANSAS HISTORIC DISTRICT COMMISSION

April 26, 2021 • 5:30pm • 1111 Main Street



City of Conway HISTORIC DISTRICT COMMISSION

April 26, 2021

Due to restrictions imposed because of COVID-19, the Historic District Commission meeting will be broadcast on the City of Conway [Facebook](#) and [YouTube](#) pages. Please submit questions/comments via [email to Planning Staff](#) by 3:00pm the day of the meeting.

MEMBERS

Steve Hurd, Chairman
Emily Walter, Vice-Chairman
Shelby Fiegel, Secretary
Marie Cason
Liz Hamilton
Shane Lind
Margaret West

Call to Order.

Roll Call.

Approval of Minutes. March 22, 2021

I. Public Hearing Items - Robinson Historic District

- A. 819 Mitchell Street - New single-family residence (HDC2021APR01)
- B. 928 Center Street - Greeson-Cone House Exterior Renovations (HDC2021APR05)

II. Public Hearing Items -Old Conway Design Overlay District

- A. 530 Davis Street - Exterior Modifications (HDC2021APR02)
- B. 619 Mitchell Street - Exterior Modifications (HDC2021APR03)
- C. 766 Harkrider Street - Interim building (HDC2021APR04)

Adjourn.

819 Mitchell Street - New Single-Family Residence

HDC2021APR01 - Robinson Historic District

I.A

APPLICANT/OWNER

Leo & Lynne Crafton
550 Chestnut St
Conway, AR 72032

DESIGNER

Mike Velte / Quality Designs, Inc.
930 Wingate St, A-1
Conway, AR 72034

CONTRACTOR

Hal Crafton / Rush-Hal
3200 Tyler St
Conway, AR 72034



SITE

Address. 819 Mitchell St.

Present Zoning. R-1 (One-Family Residential), Robinson Historic District.

Abutting Zoning. South/East/West: R-2A (Two-Family Residential), Robinson Historic District; R-1 (One-Family Residential), Robinson Historic District.

Lot Area. 0.47 acres ±.

Surrounding Area Structures. The property is located in the Robinson Historic District on the west side of Mitchell St. Area structures consist of single family residences in contemporary, colonial revival, "Garrison" colonial revival, craftsman, and a mid-century church facility. The property rests within an area of highly detailed, prominent homes.

General Description of Property and Proposed Development. The applicant is proposing to construct a new 3,340 sf single-family residence and 1,742 sf garage and porch. The proposed structure will be of a contemporary style.

Setbacks. Front setbacks are allowed within a range of 85% to 115% of the average front setback of the area. The average setback from the property line for the area is 28'. The included drawings indicate a setback of 29'. The other proposed setbacks conform to the zoning requirements.

The proposed setbacks and spacing are appropriate.

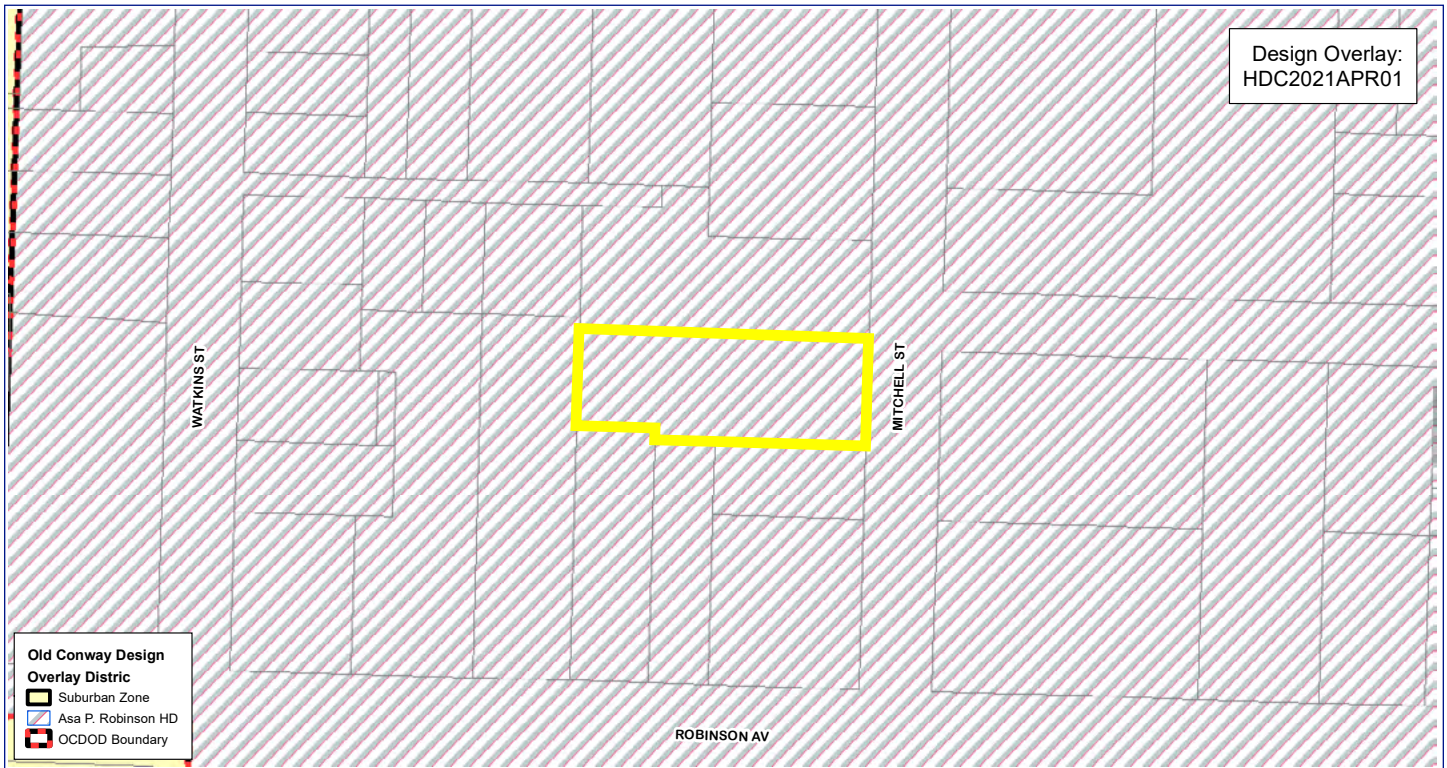
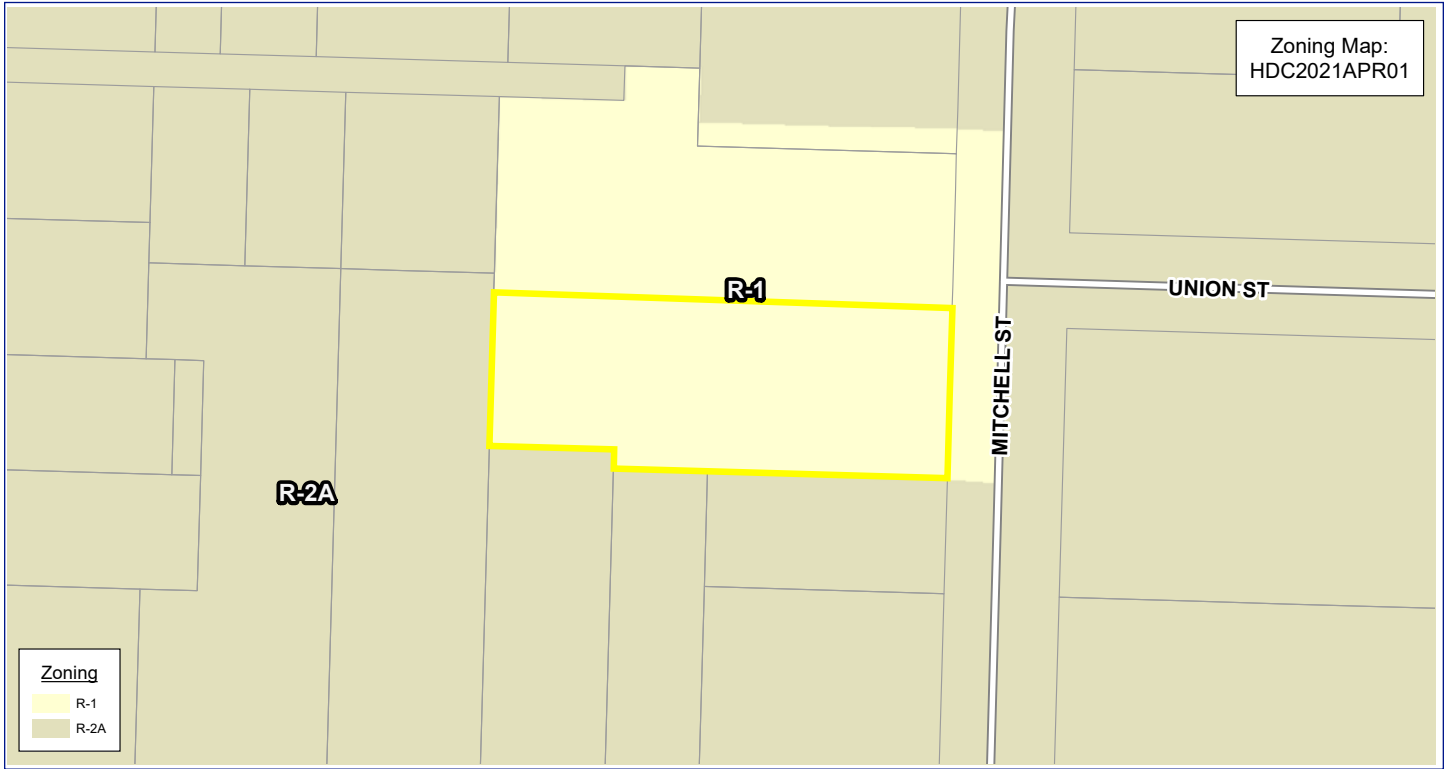

Spacing. New construction should follow established spacing distance pattern between area structures.
Spacing is similar to other residences and fits within the neighborhood spacing pattern.

Lot Coverage. Lot coverage for all impervious surfaces shall be less than 60%.
Lot coverage for the site is approximately 27%.

Orientation. The front door of the structure should follow the orientation of entries along the street.
The front door faces the street in a similar fashion to other structures on the street.

Alley. There is no alley access to this lot.

Driveway/Parking/Garage. Parking in the front yard is not appropriate. Driveways should be concrete, pavers, or permeable paving. Garages should be clearly secondary to the primary structure and complement the primary structure.

The applicant is proposing a 12' driveway along the south side of the property. The driveway's placement will place it immediately adjacent to the driveway to the south. Recommend requiring the driveway be reduced in size to match the 10' driveway to the south and moved approximately 3' to north with a 2' buffer from the house for plantings and to allow a green strip between the driveways. However, placement at the street should share the existing driveway apron or the existing driveway should be modified and reduced in size.

Sidewalks. There is an existing sidewalk along the property.
Sidewalk construction is not required.

Fences/Walls. No fencing is proposed.
If fencing is to be constructed, it will need approval by the HDC.

Tree preservation. There appears to be one significant trees which might be affected by this project. Understory trees shall be required for each 30' of street frontage.

The applicant is proposing to remove the existing significant tree in the front yard. Due to utility conflicts it has been oddly and over-pruned in the past. Recommend requiring one understory tree to replace the tree to be removed in addition to the two understory trees which are required.

MASSING

Scale. The scale of the building should maintain the relationship of the structure's scale to the lot size of surrounding buildings.
The scale of the proposed structure (5,082 sf) is compatible to the overall scale of structures in the surrounding area, which appear to range between approximately 2,650 sf and 5,363 sf.

Height. The structure should respect the historical norms within the neighborhood.
The structure shall be 2 story. Most structures within the area 2 stories.

Width. The structure should respect the average width of homes within the general vicinity.
Surrounding homes appear similarly wide with structures exceeding 60' in width and some as little as 45'. The home will have a width of 47'.

Directional expression. The structure should respect the directional expression of homes within the general vicinity.
Many of the homes in the immediate vicinity are strongly horizontally prominent similar to the proposed structure

Footprint. The structure should respect the ratio of building footprint to lot area of homes within the general vicinity.
The building footprint will cover less than 30% of the site, like other structures in the area.

Complexity of form. The detailing and wall breaks should relate well to structures in the area.

The structure will contain a pattern of wall breaks that will help reduce the feel of the large size of the structure and make it feel more compatible to the neighborhood.

Façade, wall area, rhythm. New façades shall be compatible with those of the surrounding area. Front façades should contain a similar ratio of windows and openings to that of area structures. Window and door openings should relate to the size and proportions contained in the surrounding area.

The proposed structure will contain far fewer window openings compared to surrounding structures. Window openings are highly prominent for all surrounding structures. However, the deep covered porch will help reduce the visual impact of this.

Recommend requiring at least 25% of the front and side façades (excluding the garage area) be composed of window openings. This would include the addition of a window along the front façade on the north side of the structure. This would also include additional windows along the side façades including an opening in the alcove on the north side façade.

DESIGN ELEMENTS

Style. New structures should respect the context of the area while expressing the contemporary nature of the structure.

The style of the home will be of a contemporary English Revival style. The structure will have a compatible appearance without conveying a false sense of historicity.

Entries, Porches, and Porticos, Doors and Windows, Awnings. Porches are encouraged and should be at least 6' deep, when present. Entries should contain special decorative elements and ornamentation. Windows should be of divided-light construction, where divided-light windows are proposed. Fake muntins are not permitted.

The front entry appears appropriately substantial for the area. Windows will require true divided lights. The addition of shutters is not consistent throughout the structure and appear very conjectural. Recommend requiring removal of the shutters.

Lighting. Any new lighting should be inward, downward, and shrouded so as to stay within the bounds of the property.

No lighting is shown on submitted plans.

MATERIALS & DETAILING

Architectural Details, Siding, and Bricks. Detailing and siding should complement the surrounding area. Siding should include brick, stone, wood, or Hardieboard/LP Smartside type siding.

Siding is proposed as brick with wood detailing. Fascias and soffits should be required to be of wood or Hardieboard construction.

Shutters, Roof, Decks/Plaza Space, Skylights, Mechanical Screening. Roofing should respect the character of the surrounding area with respect to materials, pitch, and form. Metal roofing is prohibited unless historically used on the structure.

The roof form is more highly complicated than typically seen within the surrounding area or for the style, but appears appropriate.

RECOMMENDATIONS

Staff recommends approval of the new residence and garage with the following conditions:

1. Require planting of 3 understory trees in the front yard.
2. Require the driveway be reduced to 10' and moved approximately 3' to the north with a 2' buffer from the house for plantings. However, placement at the street should share the existing driveway apron or the existing driveway should be modified and reduced in size.
3. Require at least 25% of the front and side façades (excluding the garage area) be composed of window openings. Including the addition of a window along the front façade on the north side of the structure, and additional windows along the side façades including an opening in the alcove on the north side façade.
4. Require true divided light wooden windows.
5. Require fascia and soffits to be finished with wood or Hardieboard construction.
6. Any fencing will require HDC approval.
7. HVAC equipment be placed in a manner to minimize its visibility from the street.
8. The applicant will provide revised plans to the Planning Director for review and approval prior to issuance of building permits.

I am planning on all brick with slurry paint, wooden exterior doors and windows and Hardie board trim.

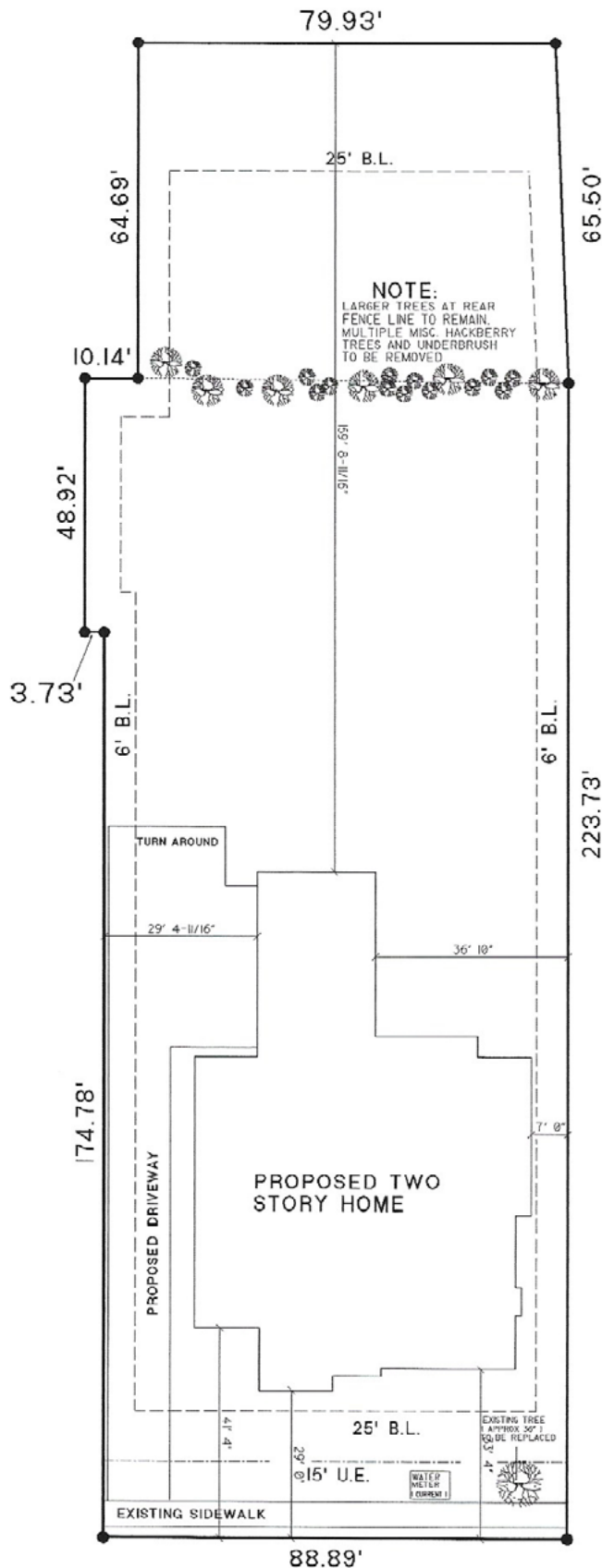

#819 MITCHELL STREET
LOT 3 JAYS REPLAT
Leo and Lynn Crafton

NOTE:

It is the responsibility of the owner/builder/contractor to verify all lot easements and private easements and setbacks before construction. Quality designs is not responsible for any setbacks or private easements that are not shown on the survey plat.



819 Mitchell Street - New Single-Family Residence

HDC2021APR01 - Robinson Historic District

I.A

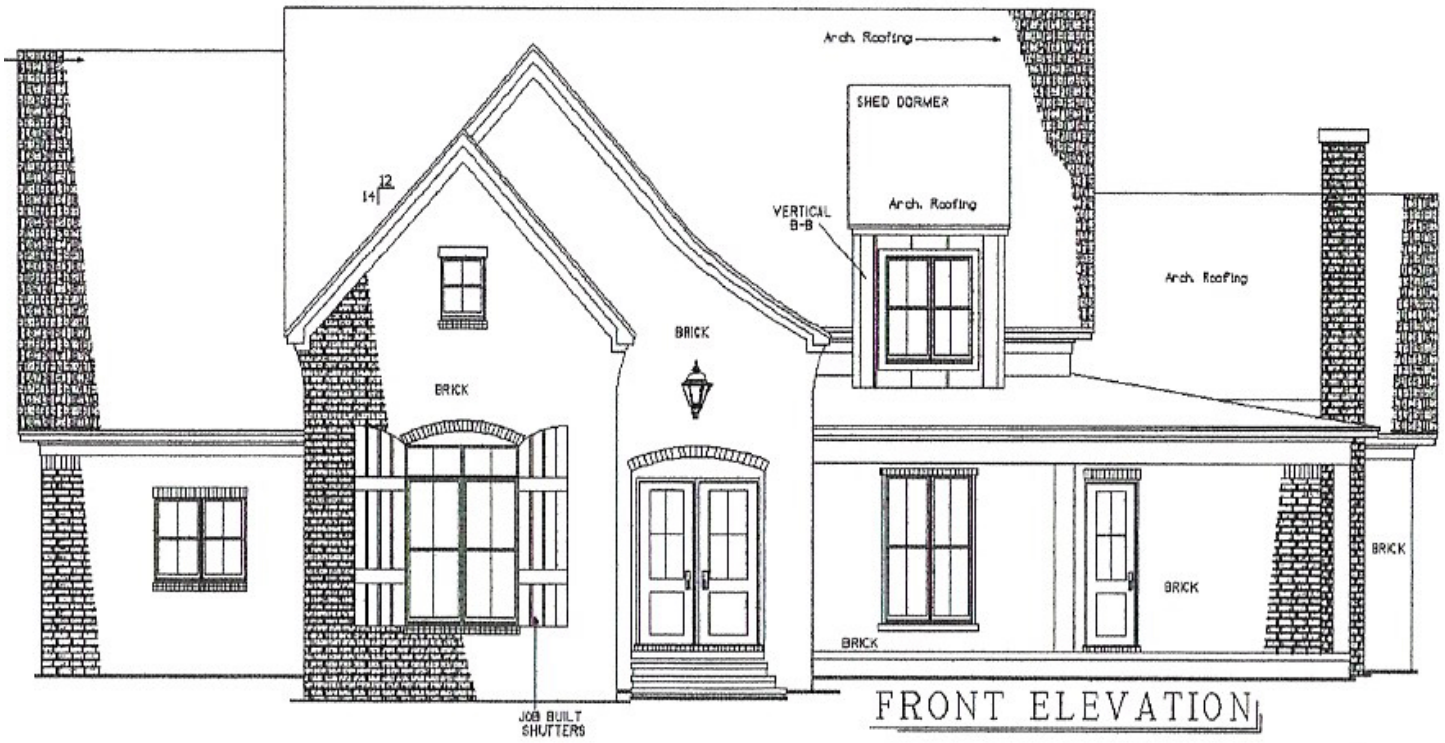



REAR ELEVATION

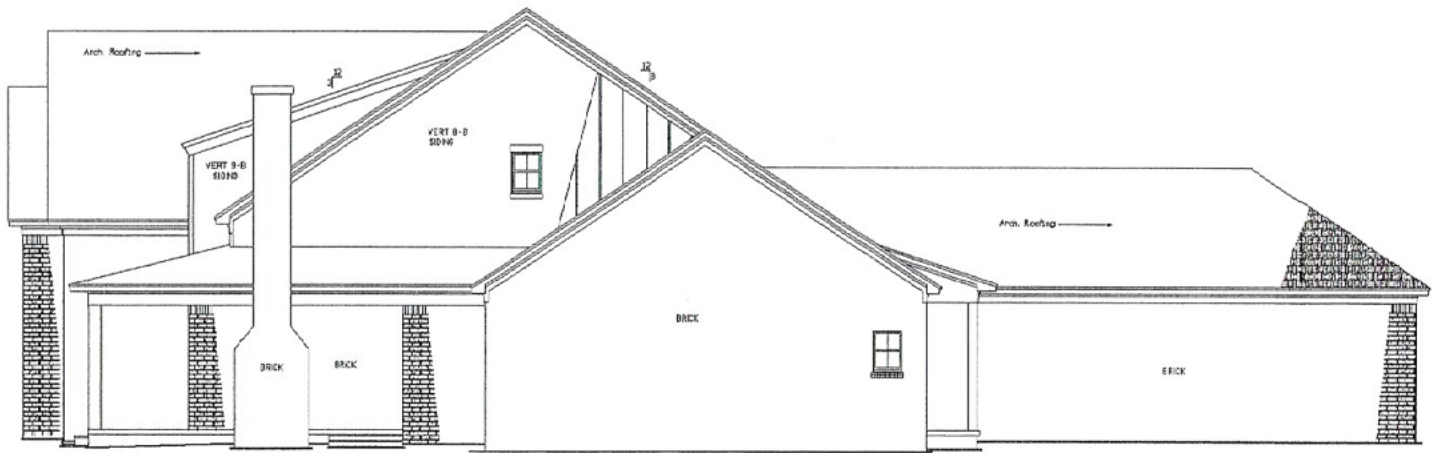

RIGHT ELEVATION

819 Mitchell Street - New Single-Family Residence

HDC2021APR01 - Robinson Historic District

I.A



View of subject property looking W



Property adjacent to the S



Property adjacent to the N



Property adjacent to the NE



Property adjacent to the E

928 Center Street - Greeson-Cone House - Exterior Modifications

HDC2021APR05 - Robinson Historic District

I.B

APPLICANT/CONTRACTOR

Stephen Eifling / Oasis Construction, LLC
1717 Southern Hills Dr
Conway, AR 72034

OWNER

Kimberly Mulkin
928 Center St
Conway, AR 72034



SITE

Address. 928 Faulkner St.

Present Zoning. R-2A (Two-Family Residential), Robinson Historic District.

Abutting Zoning. North/West/South: R-2A (Two-Family Residential), Robinson Historic District; East: O-3 (Restricted Office), Robinson Historic District.

Lot Area. 0.31 acres ±.

Surrounding Area Structures. The property is located in the Robinson Historic District on the east side of Center St.

- West – 931 Center St: H.H. Bumpers House (Spanish Revival; Contributing) and 923 Center St: House c.1927 (Traditional English Revival; Contributing)
- North – 934 Center St: W.G. Darwin House 1939 (Colonial Revival; Contributing)
- East – 931 Faulkner St: House c.1935 (Traditional Colonial Revival; Contributing)
- South – 920 Center St: O.L. Dunaway House (Colonial Revival; Contributing)

928 Center Street - Greeson-Cone House - Exterior Modifications

HDC2021APR05 - Robinson Historic District

I.B

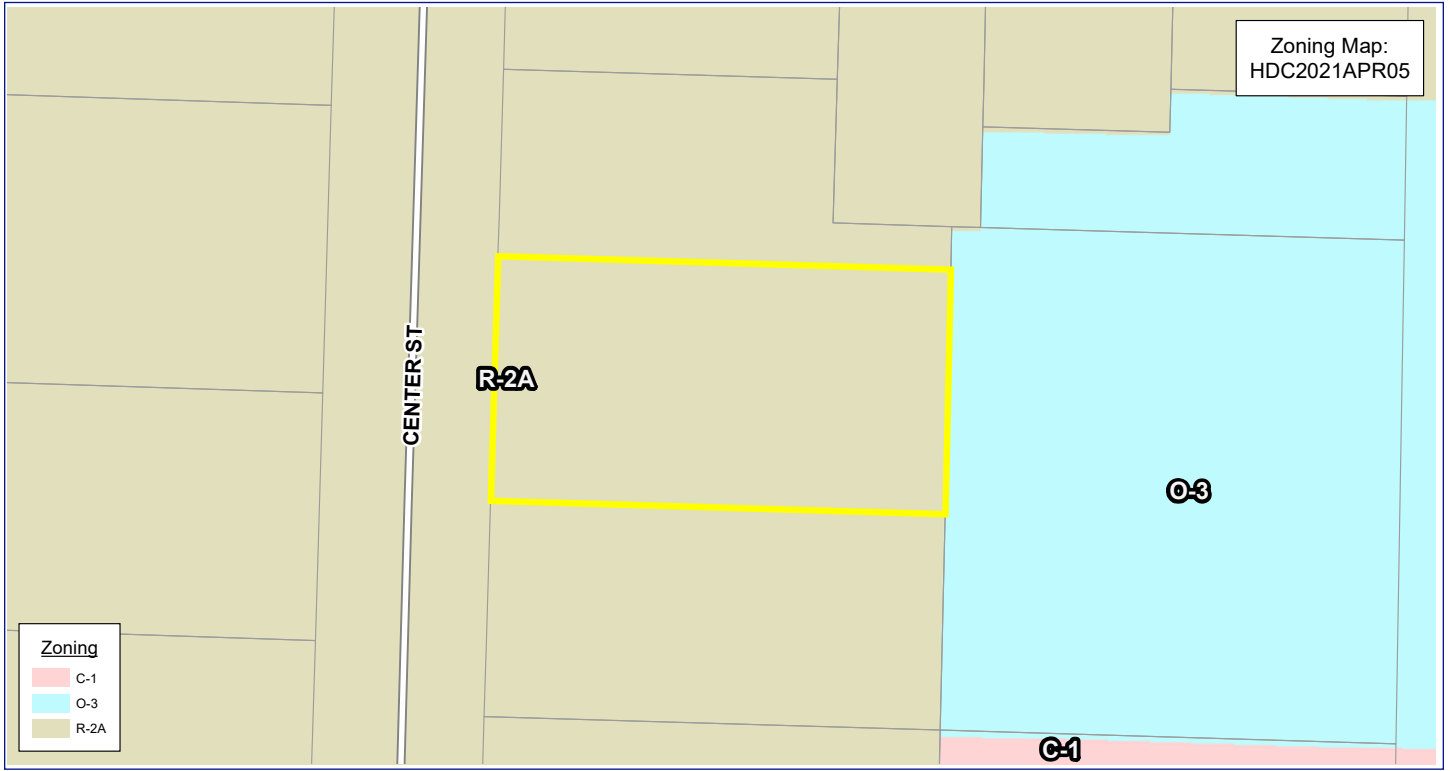

General Description of Property and Proposed Development. The Greeson-Cone House was constructed in 1920 in the Craftsman style. The structure was listed as contributing in early 1998 when the district was surveyed. The house was listed on the National Register of Historic Places in 1995.

The applicant is proposing to remove the existing staircase at the rear of the structure and construct a new staircase. The existing staircase was present at the time the district was surveyed in 1998, though it is likely not original to the house. The staircase is at the rear of the structure with only a small portion of the side being visible from the public right-of-way.

DESIGN ELEMENTS

Entries, Porches, and Porticos, Doors and Windows, Awnings. Porches are encouraged and should be at least 6' deep, when present. Entries should contain special decorative elements and ornamentation that is historically supported or appropriate to the style. Windows should be of divided-light construction, where divided-light windows are proposed. Fake muntins are not permitted.

The proposed replacement staircase and railing are located at the rear of the structure and do not represent an exact match of what would have been historically placed on the structure. This approach is appropriate to the structure such that it helps denote that it is not an historic element on the home. The majority of the staircase is not visible from the public right-of-way therefore the proposal is appropriate.

Though not proposed, Staff recommends prohibiting the addition of lattice or similar screening to staircase structure or railing, as it is present on the existing staircase.

RECOMMENDATION

Staff recommends approval with the following condition.

1. The use of lattice or similar screening material is prohibited.

928 Center Street - Greeson-Cone House - Exterior Modifications

HDC2021APR05 - Robinson Historic District

I.B

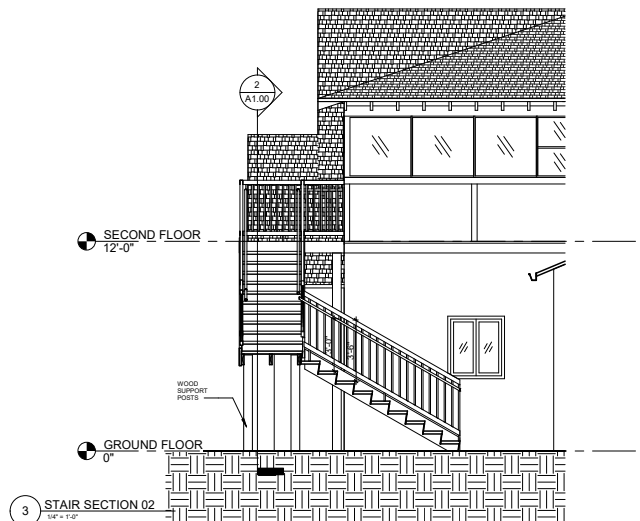
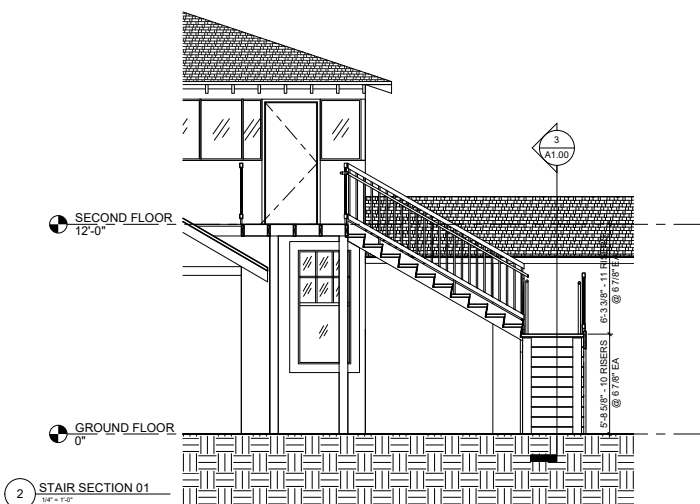
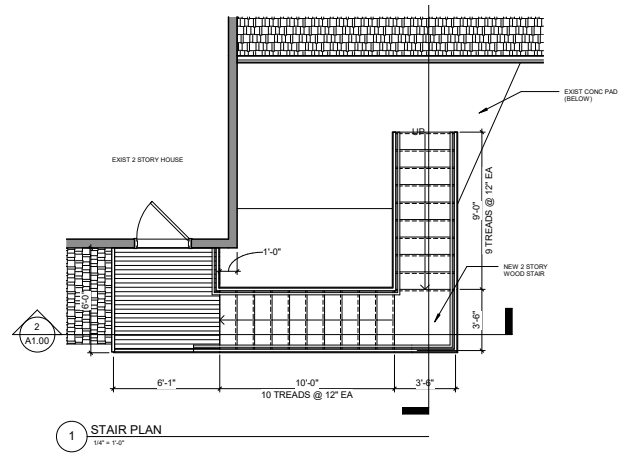
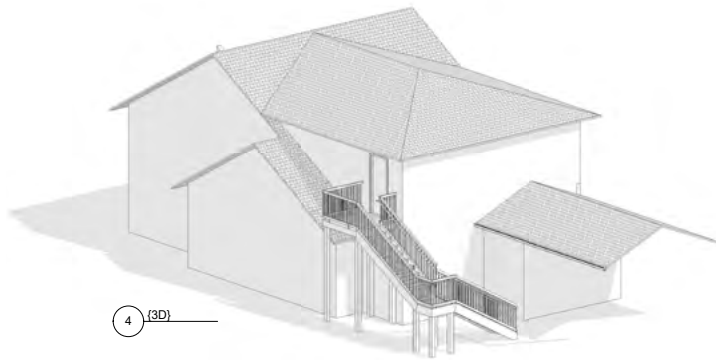
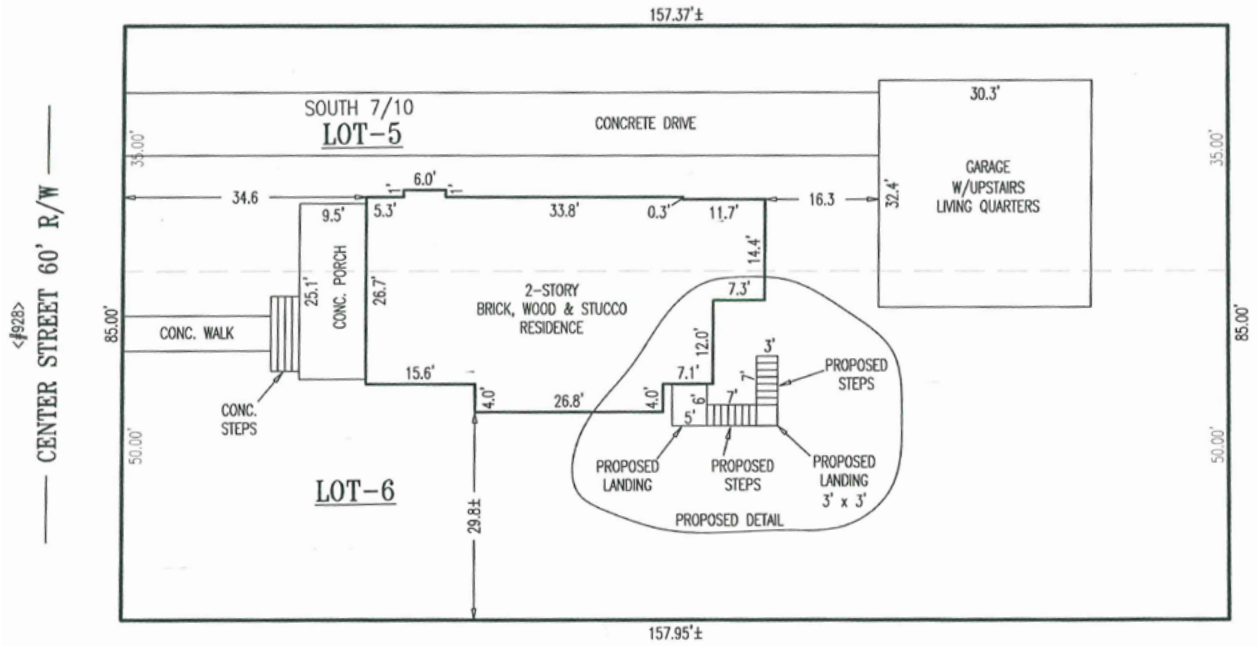



Existing staircase to be removed



928 Center Street - Greeson-Cone House - Exterior Modifications

HDC2021APR05 - Robinson Historic District

I.B

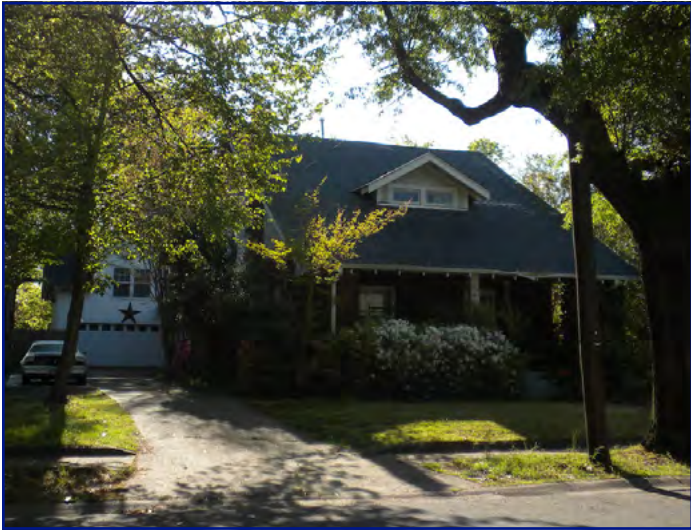

View of subject property looking SE



View of subject property looking NE



Property adjacent to the N

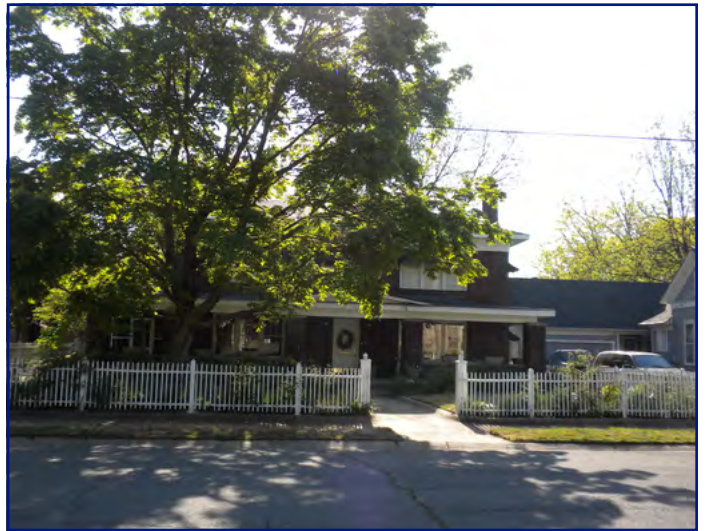

Property adjacent to the S



Property adjacent to the W



Property adjacent to the E

APPLICANT/OWNER

Phillip & Marion Bailey
530 Davis St
Conway, AR 72034



SITE

Address. 530 Davis St.

Present Zoning. R-2A (Two Family Residential), Old Conway Design Overlay District Suburban Zone.

Abutting Zoning. R-2A (Two Family Residential), Old Conway Design Overlay District Suburban Zone.

Lot Area. 0.56 acres ±.

Surrounding Area Structures. The property is located in the Old Conway Design Overlay District Suburban Zone on the east side of Davis St between Scott St and College Ave. Area structures consist of single-family residences in Colonial Revival, Craftsman, Contemporary, and Minimal Traditional Styles.

General Description of Property and Proposed Development. The applicant is proposing to add a partially covered deck to the rear of the home. The applicant commenced work prior to obtaining a Certificate of Appropriateness or Building Permits.

Style. New design should respect the context of the area while expressing the contemporary nature of the structure.

The alteration will be a conjectural element added on to the house, however, there is precedent for covered decks. To maintain consistency in design, wide trim matching existing style of window trim on the opening should be used to surround the overall opening for the new entry.

530 Davis Street - Exterior Modifications

HDC2021APR02 - Old Conway Design Overlay District

II.A

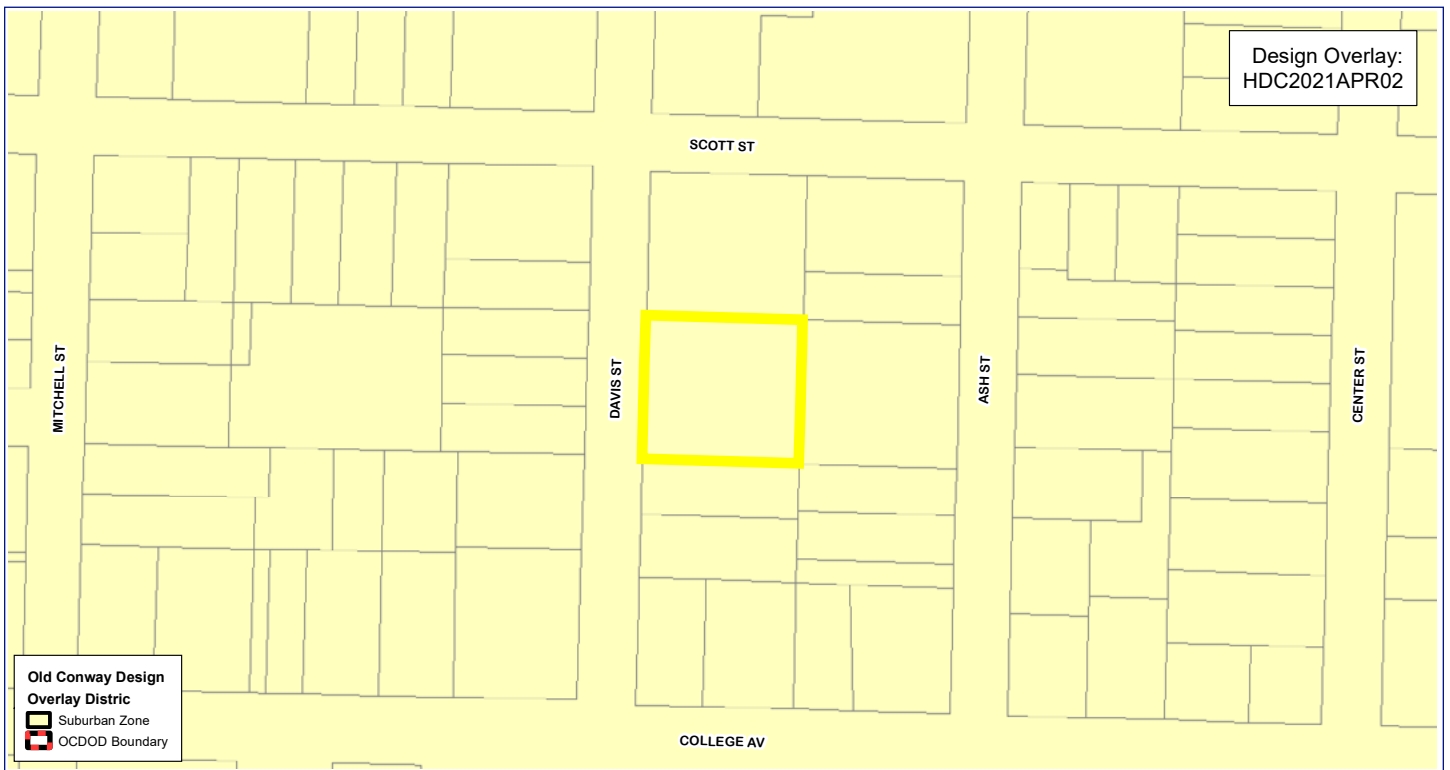
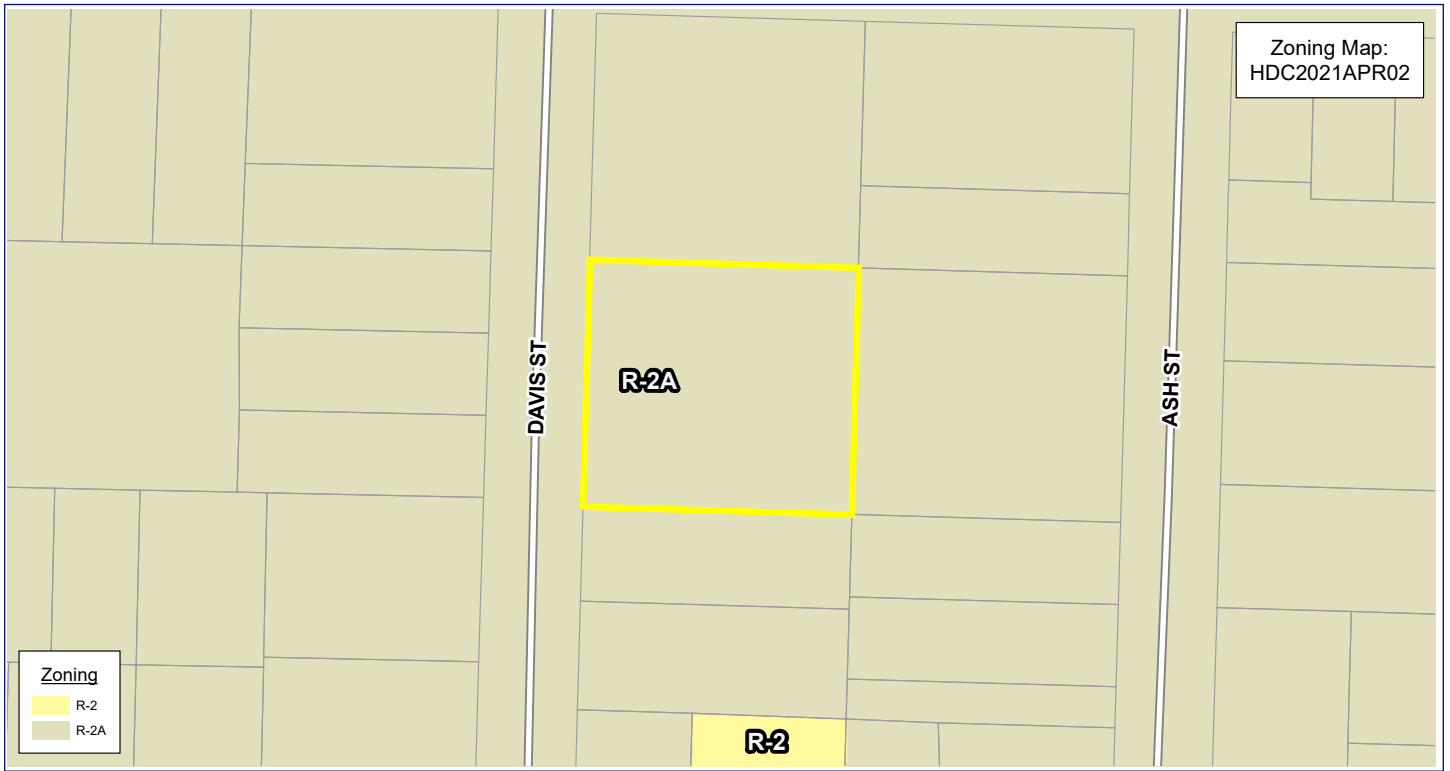

MATERIALS AND DETAILING

Roofs. Roofing should respect the character of the surrounding area with respect to materials, pitch, and form.

The proposed covered deck on the rear elevation will match the existing pitch of the roof with matching shingles. The end gable will include a contemporary design to help distinguish it from the existing structure.

Decks/Balconies. Elevated wooden decks are not historic to the area and should be located at the rear of the structure and screened from street view with fencing and/or plants and shrubs when visible.

The applicant is proposing to construct the deck at the rear of the structure within a fenced and wooded yard.

RECOMMENDATIONS

Staff recommends approval of the application with the following conditions:

1. Require the structure be constructed with detailing as submitted.
2. The addition and all work must fully comply with all Building Codes.

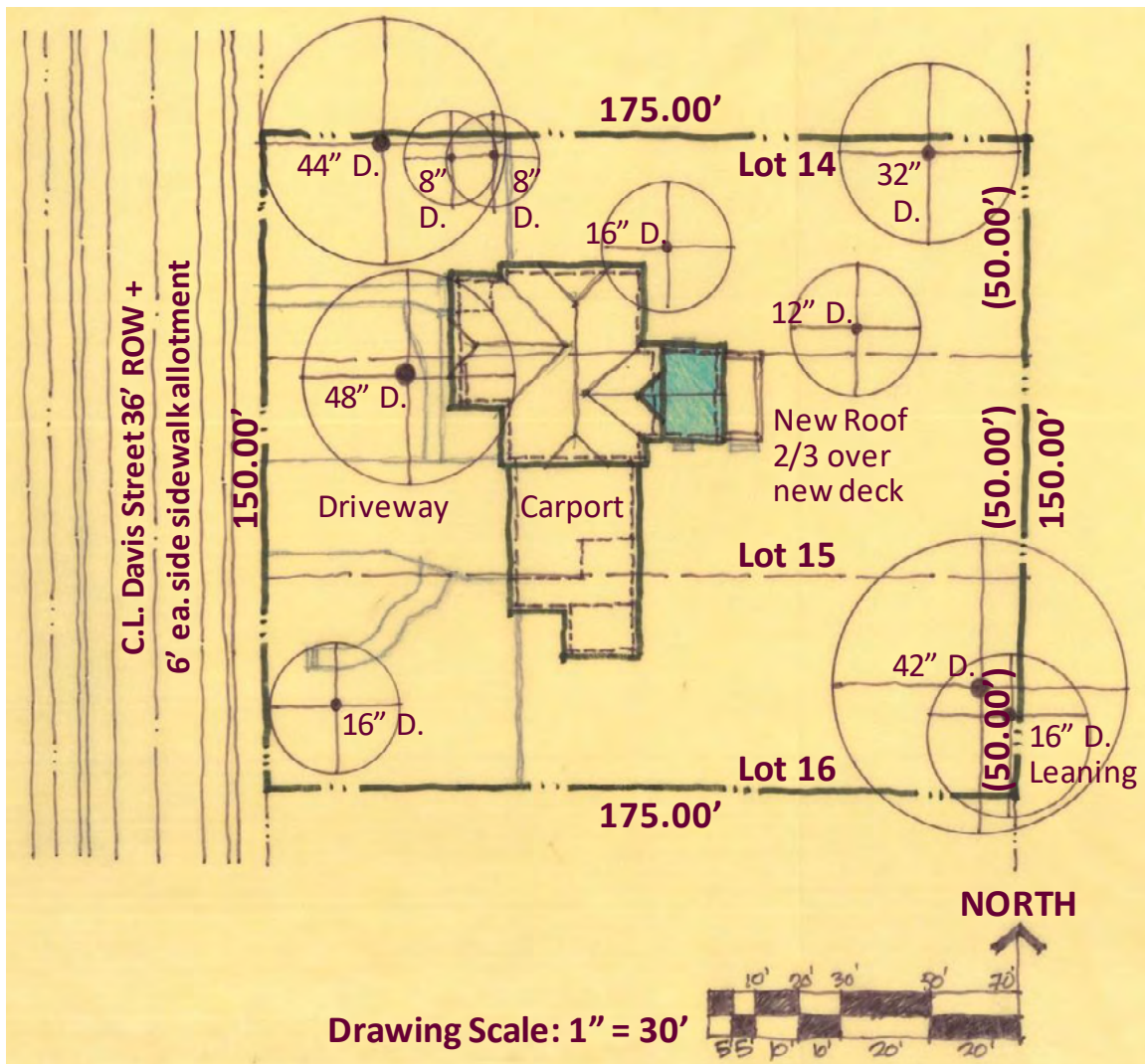
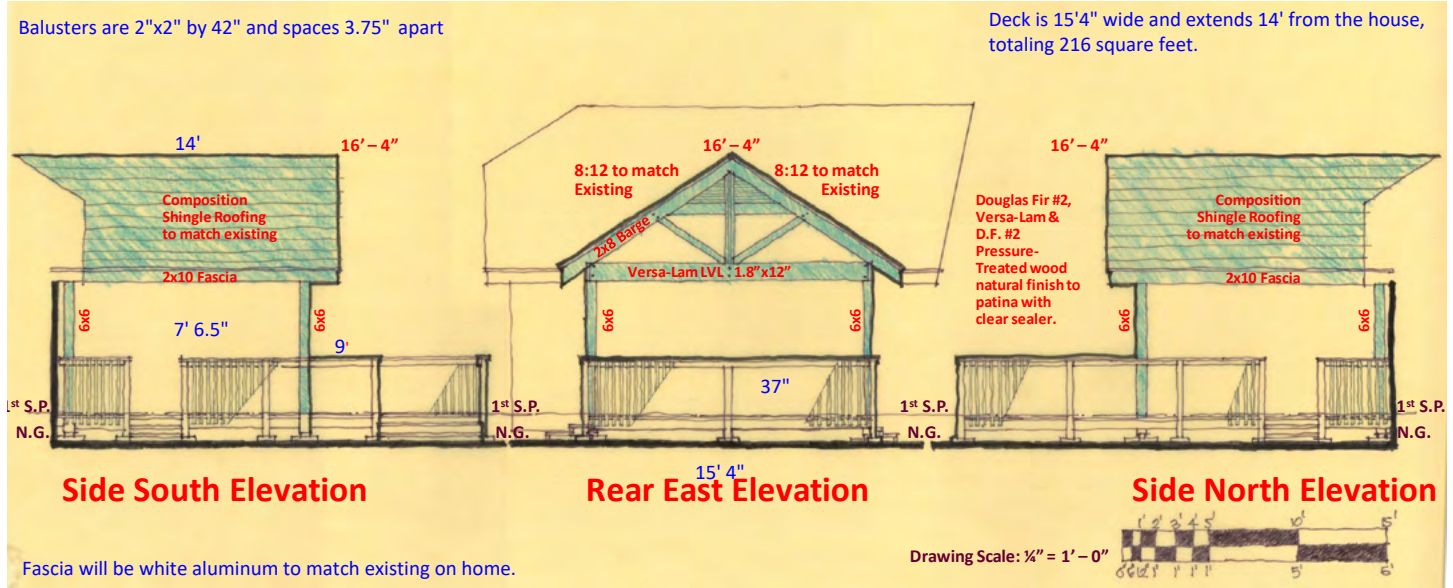

530 Davis Street - Exterior Modifications

HDC2021APR02 - Old Conway Design Overlay District

II.A



View of subject property looking E



View of subject property looking E



Property adjacent to N



Property adjacent to the S



Property adjacent to the W



Property adjacent to the W

619 Mitchell Street - Exterior Modifications

HDC2021APR03 - Old Conway Design Overlay District

II.B

APPLICANT/OWNER

Dan & Cindy Williams
619 Mitchell St
Conway, AR 72034

DESIGN PROFESSIONAL

Steve Hurd, AIA / Hurd Long Architects
1015 Van Ronkle St
Conway, AR 72032

CONTRACTOR

Jim Lary
12 Snowden Cir
Greenbrier, AR 72058



SITE

Address. 619 Mitchell St.

Present Zoning. R-2A (Two-Family Residential), Old Conway Design Overlay District - Suburban Zone.

Abutting Zoning. R-2A (Two-Family Residential), Old Conway Design Overlay District - Suburban Zone.

Lot Area. 0.47 acres ±.

Surrounding Area Structures. The property is located in the Old Conway Design Overlay District - Suburban Zone on the west side of Mitchell St between Robinson Ave and Scott St. Area structures consist of single-family residences in simplified Folk Victorian/ Queen Anne, simplified Craftsman, Contemporary, and Minimal Traditional Styles.

General Description of Property and Proposed Development. The applicant is in the process of replacing three windows on the north façade with a French door walk-up entry per approval by the HDC in February 2021. As an expansion of that project, the applicant is seeking approval to add a roof over the new side entry landing in accordance with Certificate of Appropriateness, issued February 22, 2021.

619 Mitchell Street - Exterior Modifications

HDC2021APR03 - Old Conway Design Overlay District

II.B

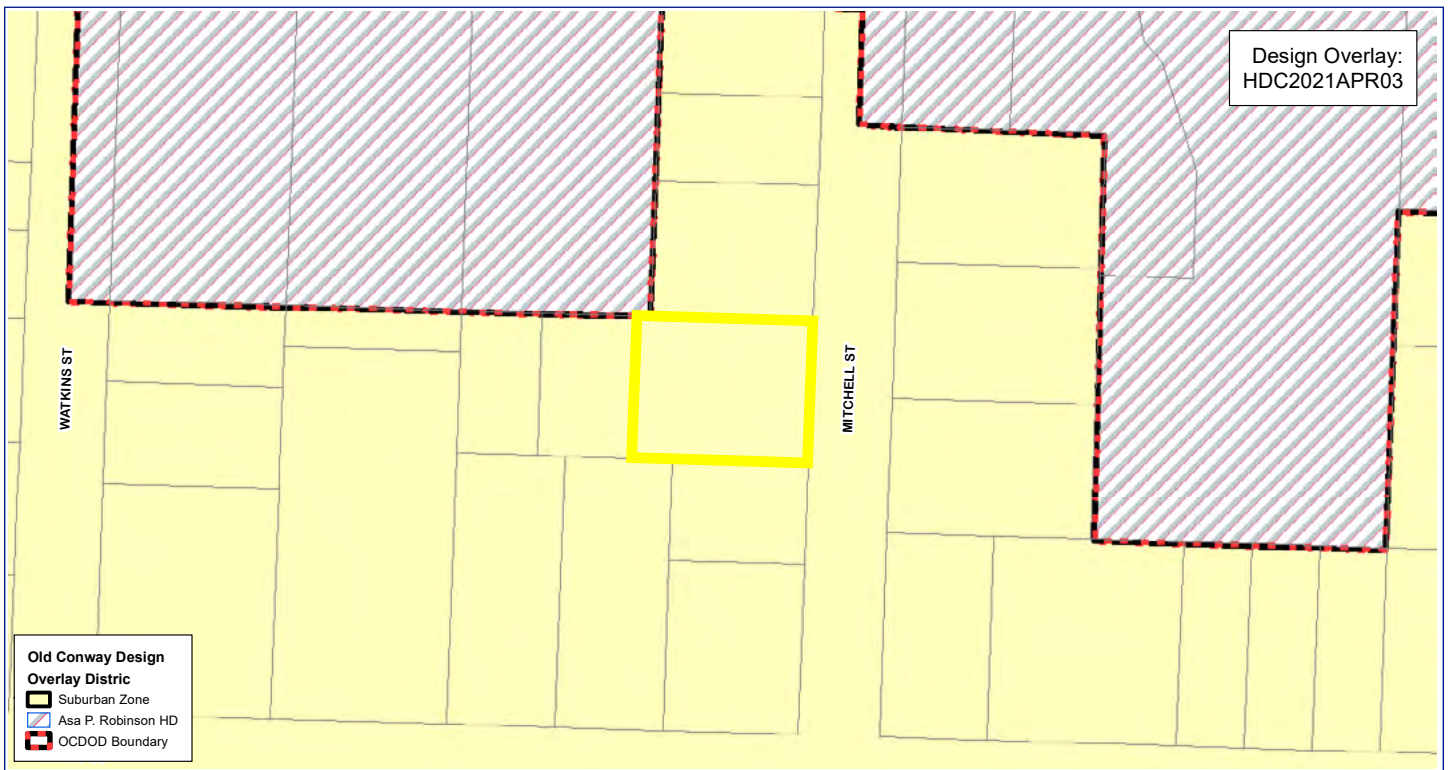
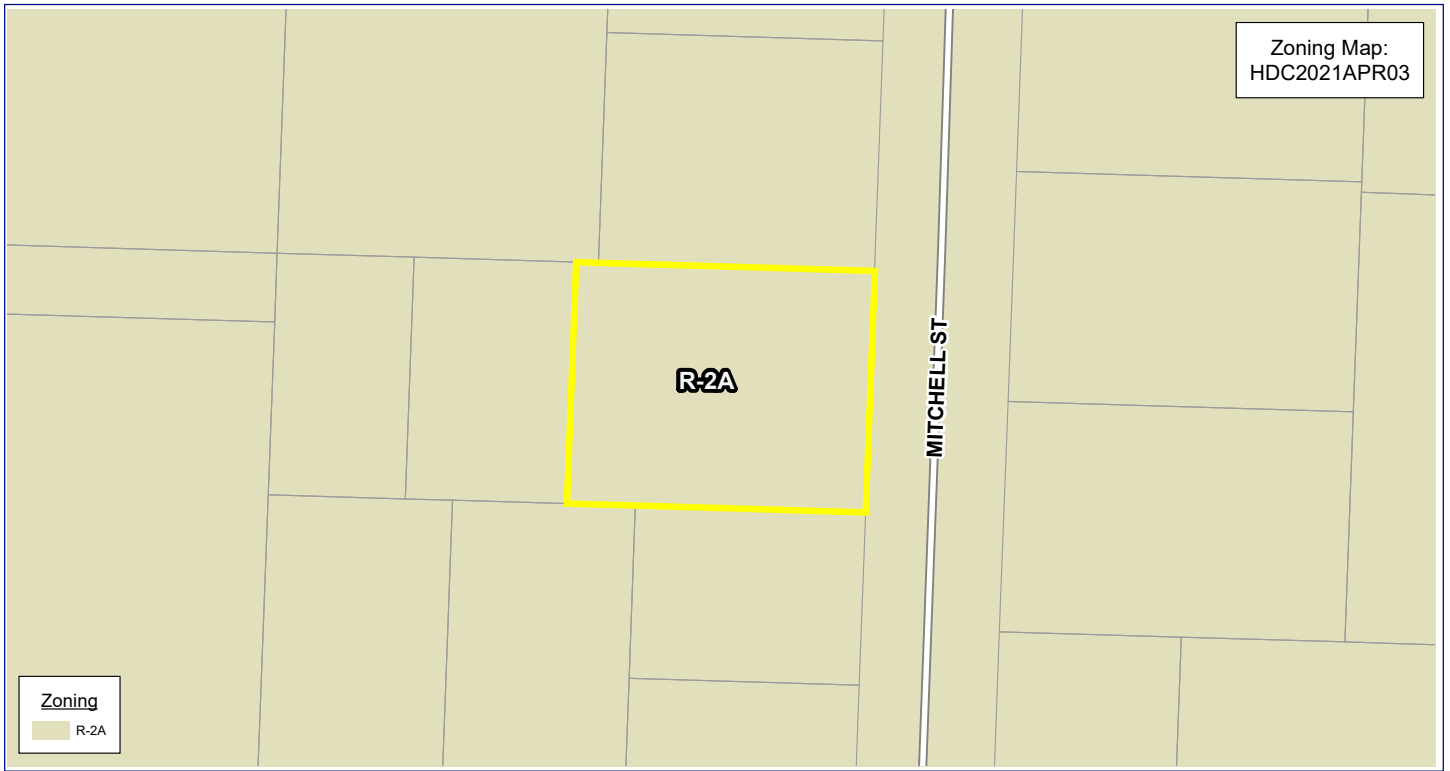

DESIGN ELEMENTS

Entries, Porches, and Porticos, Doors and Windows, Awnings. Porches are encouraged and should be at least 6' deep, when present. Entries should contain special decorative elements and ornamentation. Windows should be of divided-light construction, where divided-light windows are proposed. Fake muntins are not permitted.

The landing for the entry will use, in part, brick salvaged from repair of the chimney plus brick to match. Entry landing is proposed to be covered and will feature 10"x10" square columns with trim to match existing front porch columns.

MATERIALS & DETAILING

Architectural Details, Siding, and Bricks. Detailing should be compatible with existing elements in style, material, size, and shape.

No railing is proposed. Staff recommends if railings are added they should match the front porch in style and construction.

Shutters, Roof, Decks/Plaza Space, Skylights, Mechanical Screening. Roofing should respect the character of the surrounding area with respect to materials, pitch, and form. Metal roofing is prohibited unless historically used on the structure.

Applicant is proposing a shingle roof to match existing.

RECOMMENDATIONS

Staff recommends approval of the application with the following condition:

1. If railings for the entry are added they should match the front porch in style and construction.



Date of Historic District Commission Meeting: February 22nd, 2021

Owner:
Dan Williams
619 Mitchell St
Conway, AR 72034

Property Address / Location / Description: 619 Mitchell St

Zoning: R-2A (Large Lot Duplex), Old Conway Design Overlay Suburban District

Approved Project(s): Exterior Modifications

Conditions of Approval:

Modification shall be constructed as indicated in the approved drawings (attached)

1. Require wide trim matching the existing style of window trim on the opening for the overall entry.
2. If an addition of a railing or arbor is added at a later date, the applicant will have to resubmit plans to the commission for approval.

Termination Date: February 22nd, 2023
(If Building Permit is not issued by this date, Certificate is null and void)

Signed: 
HDC Staff / Director of Planning and Development

Attachments:

Attachment A – Elevation Drawings and Site Plans

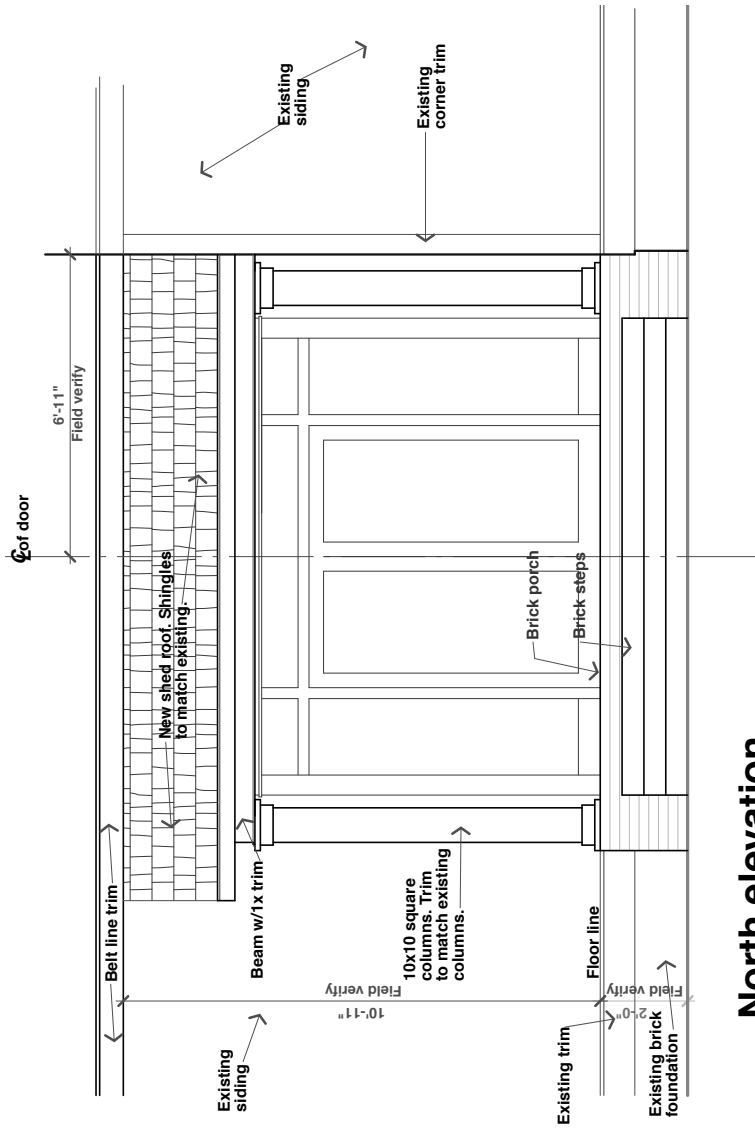

North elevation
3/8"=1'-0"

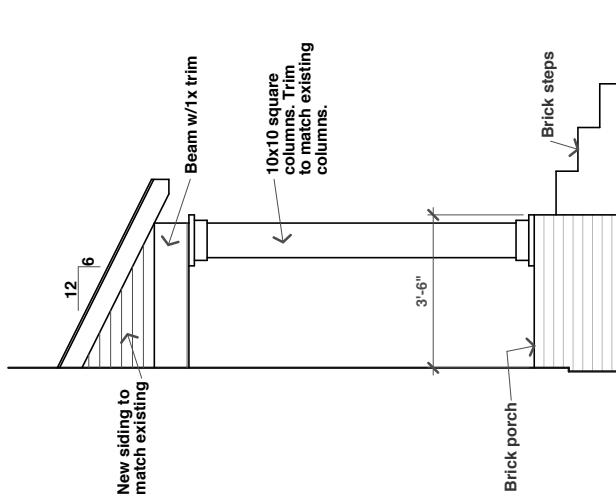

East elevation
3/8"=1'-0"

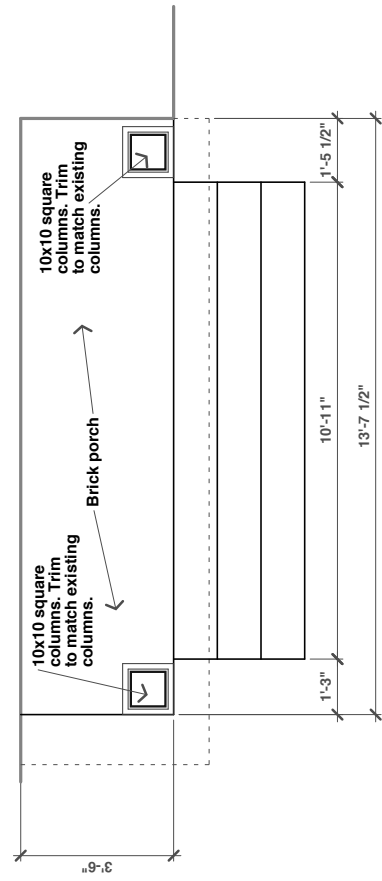

Plan
3/8"=1'-0"

New Porch
for
Dan and Cindy Williams
619 Mitchell Street
Conway, Arkansas

HERD LONG
Architects & Design Consultants, P.A.
1015 Van Ronkle Street • Conway, Arkansas 72032 • 501/336-9447
704 Billmore • Little Rock, Arkansas 72015 • 801/664-4457

619 Mitchell Street - Exterior Modifications

HDC2021APR03 - Old Conway Design Overlay District

II.B



View of subject property looking SW



View of subject property looking SW



Property adjacent to the S



Property adjacent to the N



Property adjacent to the E



Property adjacent to the E

APPLICANT/OWNER

Grant Gordy / First Community Bank
1325 Harrison St
Batesville, AR 72501

DESIGN PROFESSIONAL

RPPY Architects
713 West Second St
Little Rock AR 72201

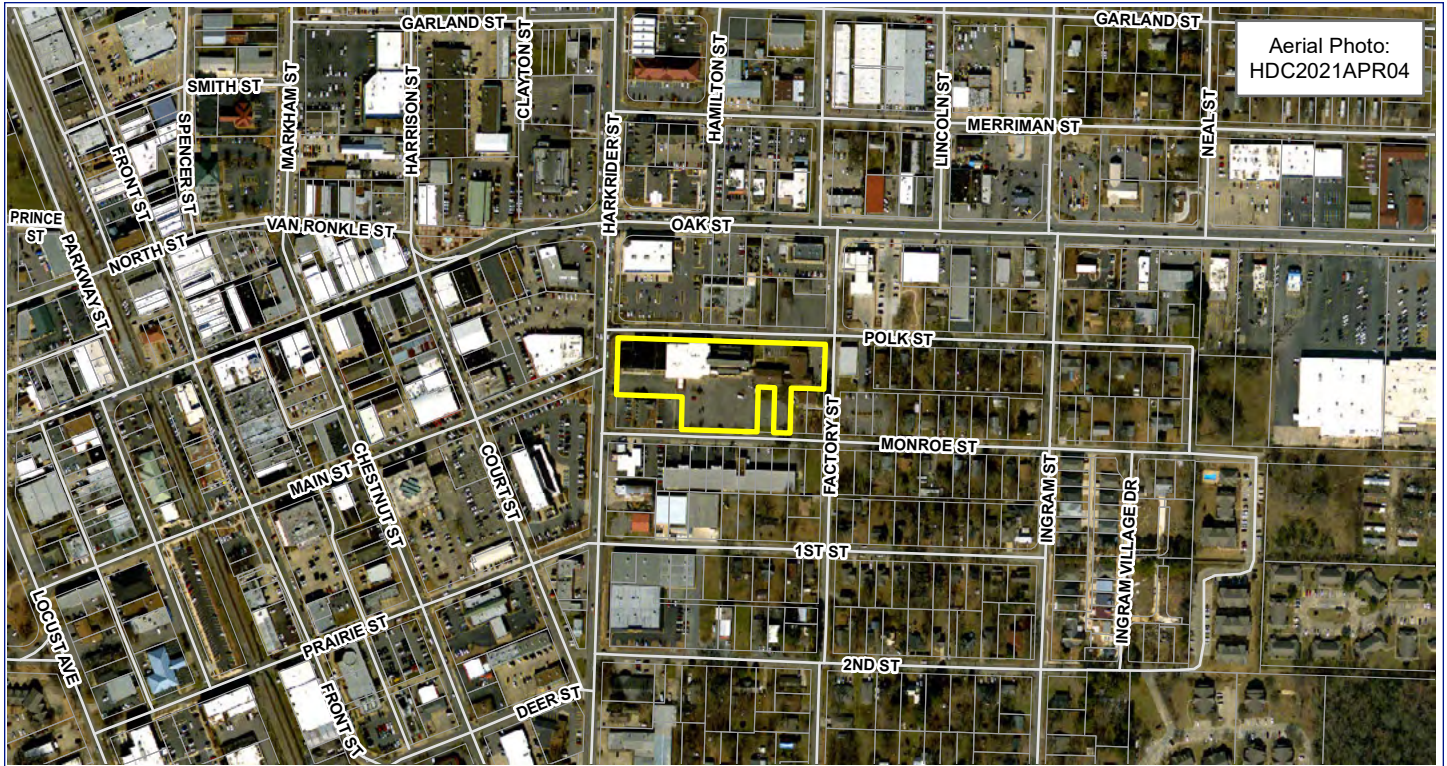

SITE

Address. 766 Harkrider St; project site is +/- 0.5 acres approximately mid-block on the north side of Monroe St.

Present Zoning. C-3 (Highway Commercial), Old Conway Design Overlay District - Transition Zone.

Abutting Zoning. C-3 (Highway Commercial) and C-1 (Central Business District), Old Conway Design Overlay District - Transition and Urban Zones.

Lot Area. 3.16 acres ±.

Surrounding Area Structures. The property is located in the Old Conway Design Overlay District - Transition Zone on the north side of Monroe St, east of Harkrider St. As the property is located at the edge of an urban, downtown area, structures consist primarily of a multi-tenant shopping center, office buildings, and a vehicle service center along with the multi-building church/education complex which previously housed various institutional uses. The extensive residential area to the east is comprised primarily of smaller single-family residences.

General Description of Property and Proposed Development. The applicant is proposing to place an approximately 1,100 sf interim building to serve as a temporary branch bank with drive-thru while the new bank/office building is being constructed. The site is currently developed as a surface parking lot which previously served the various uses of the church complex. The proposed structure will be clad with metal panels with a brick veneer at the four corners and wood entrance canopy.

766 Harkrider Street - Interim Building

HDC2021APR04 - Old Conway Design Overlay District

II.C

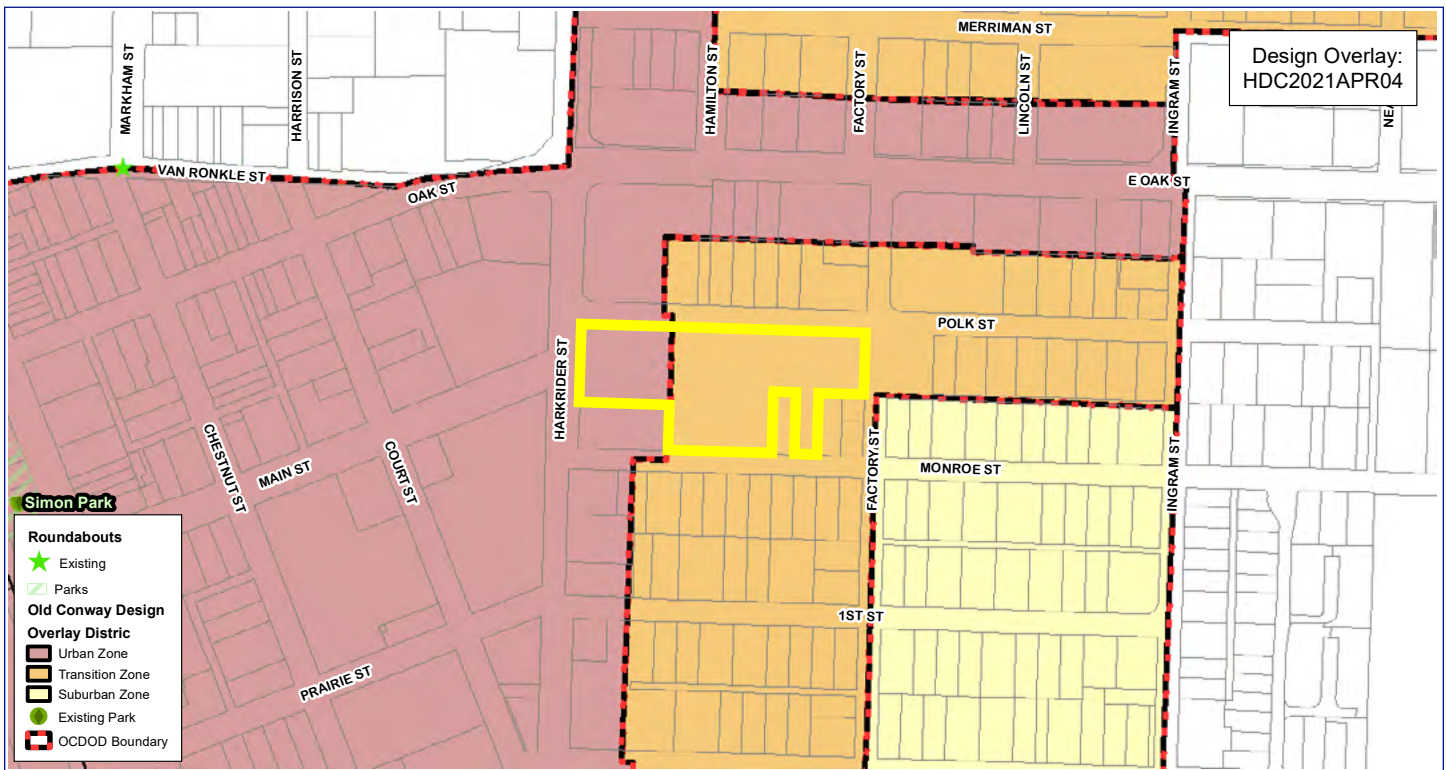
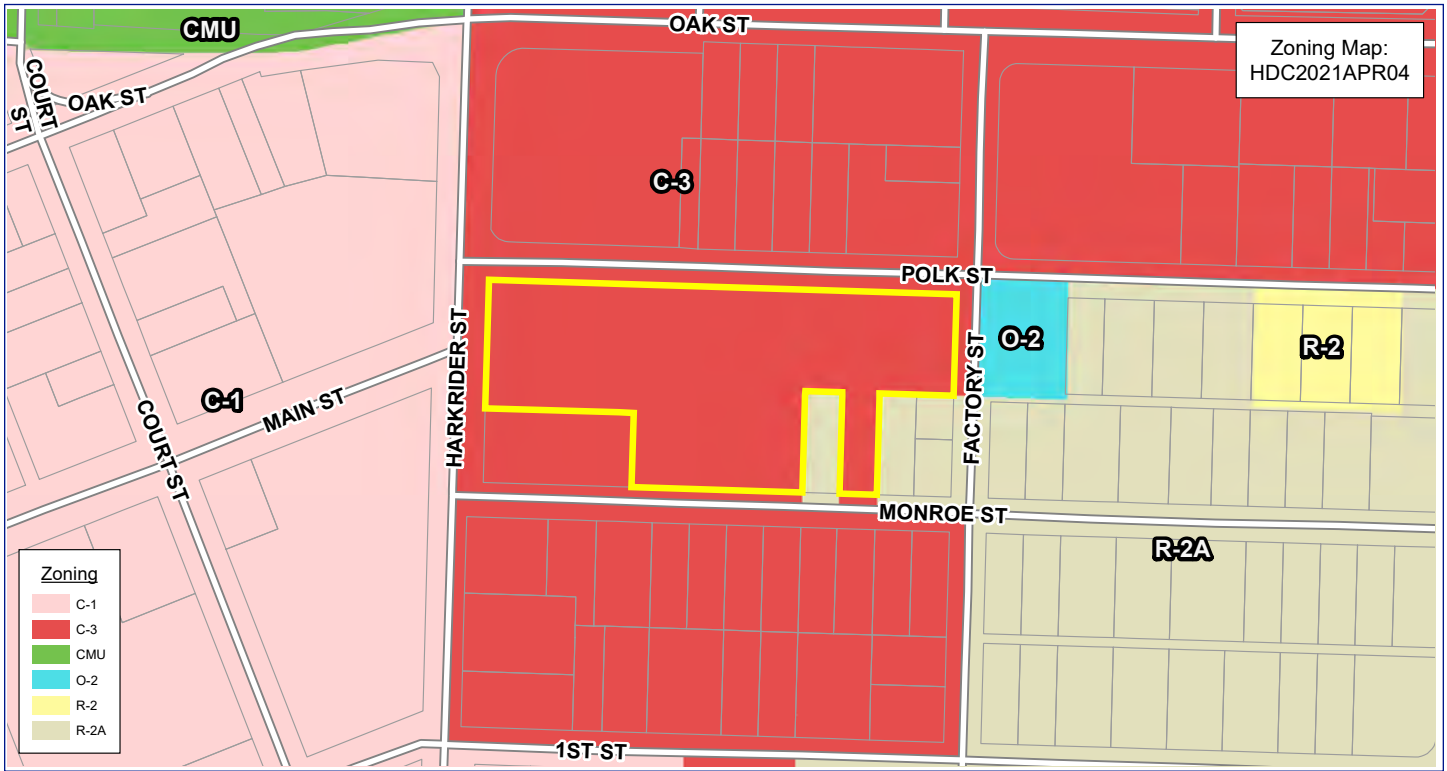

Setbacks and Spacing. Front setbacks shall be no less than 6' and no greater than 18'. The included drawings indicate a front setback of 78' from the right of way of Monroe St.

The proposed building is located beyond the required guideline setbacks, however given the temporary nature of the building, the proposed location is appropriate.

Lot Coverage. The proposed location of the structure is currently developed with a parking lot.

No increase in lot coverage is proposed.

Orientation. The front door of the building will face the Monroe St.

Driveway / Parking. The existing surface parking lot and driveways on site will remain, though orientation of parking will change. Parking lots are typically required to be located to the rear of structures.

Given the temporary nature of the building, the proposed location is appropriate. The interim building will feature a drive-thru and ATM island on the west side of the building. The drive-thru lane will que along the rear of structure in an appropriate manner.

Sidewalks. There is no existing sidewalk along the north side of Monroe St, though there is an existing sidewalk along the south side, beginning at the rear of the service station property and continuing to the end of the block. Sidewalks will be required at the time the site is permanently developed.

Fences/Walls. No fencing is proposed as a part of this request.

Tree preservation. There are no significant trees affected by the project.

MASSING

Scale. The size of the proposed structure (1,100 sf) is smaller than the overall scale of structures in the surrounding area.

The immediate surrounding buildings are larger in scale, though the residential neighborhood to the east is comprised of mostly small single-family residences. Given the temporary nature of the building the scale is appropriate.

Height. The structure appears to respect the historical norms within the neighborhood, as it is only one story.

Width. The width of structures in the area varies. The building will have a width of 48', which is smaller than the existing non-residential structures in the area, but compatible with the scale of residential development in the area.

Footprint. The footprint of the structure will be generally consistent with the surrounding buildings.

Complexity of form. The structure will contain a level of detailing and form that is more consistent with the surrounding institutional buildings rather than the residential structures in the vicinity.

Façade, wall area, rhythm. As proposed, the front façade of the structure will not meet the standards of the Overlay District, however the proposed building is temporary and will be removed after a specified period of time.

DESIGN ELEMENTS

Lighting. Any new lighting should be inward, downward, and shrouded so as to stay within the bounds of the property.

No lighting is shown on submitted plans.

MATERIALS & DETAILING

Architectural Details, Siding, and Bricks. The building will be clad in metal with brick veneer applied to the corners.

Staff recommends minimum requirements be imposed as a condition of approval.

Shutters, Roof, Decks/Plaza Space, Skylights, Mechanical Screening. The applicant is proposing a minimally sloped TPO roof. Given the nature of the temporary modular building the roofing material is acceptable. Recommend requiring that HVAC not be placed at the front of the building and be screened.

STAFF RECOMMENDATIONS

Staff recommends approval of the new structure with the following conditions:

1. The building shall be removed prior to April 27, 2023.
2. The building shall comply with Development Review standards in accordance with Article 1101 of the Zoning Code with consideration given to the building's temporary nature.
3. Appropriate interim building permit shall be obtained from the Building Permits Department.
4. HVAC equipment be placed in a manner to minimize its visibility from the street. Landscape or equivalent screening may be required.
5. Additional landscaping shall be provided along Monroe St to adequately screen parking; no trees shall be removed as part of the project.

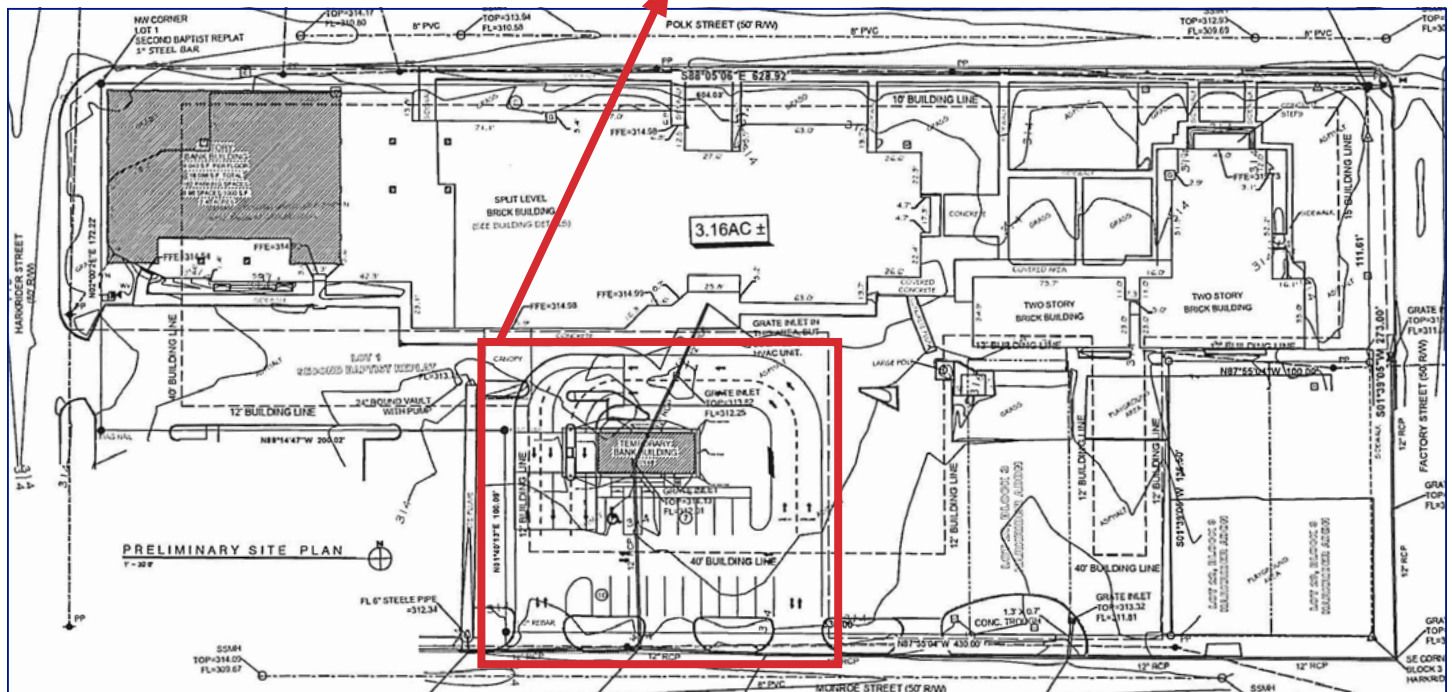
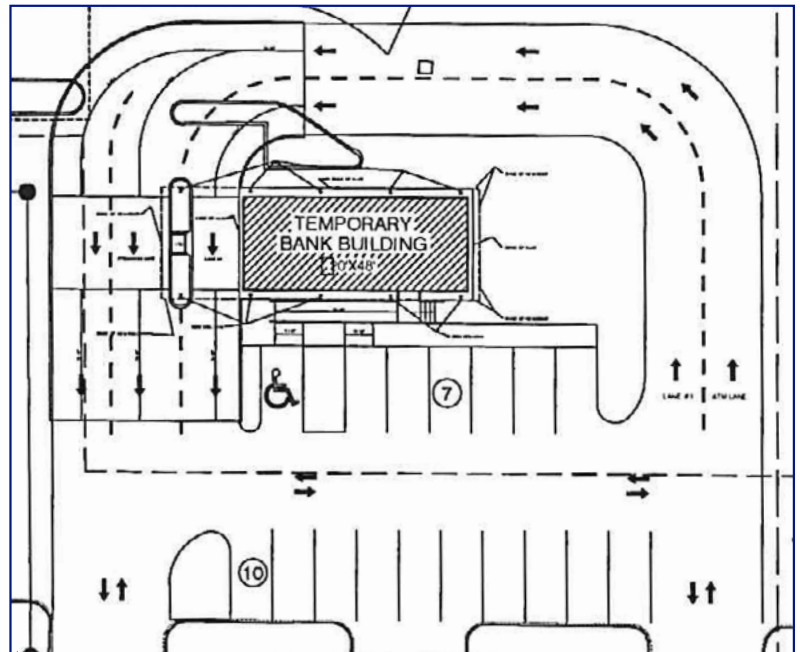

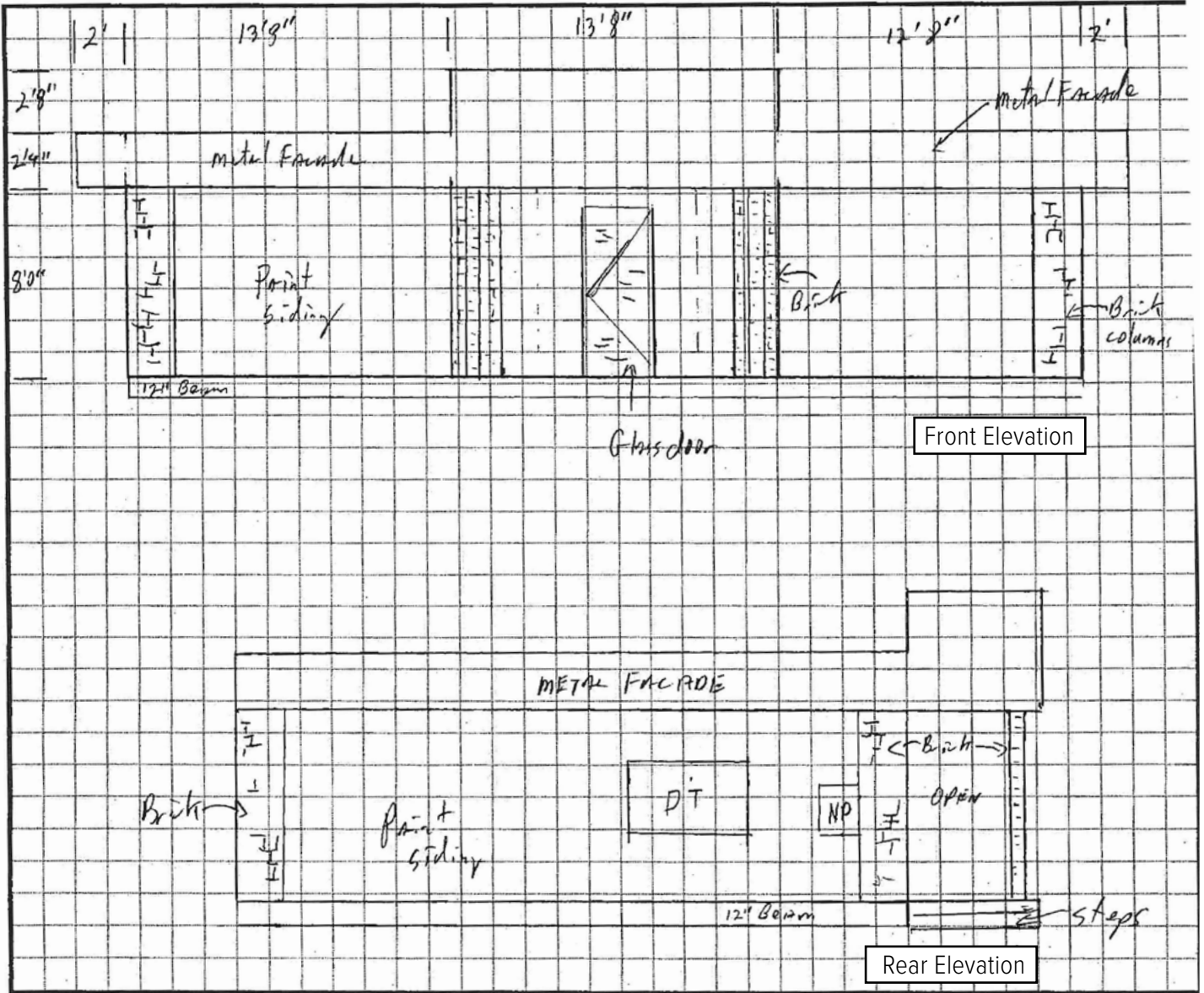



View of subject property looking NE



View of subject property looking NW



Property adjacent to the W



Property adjacent to the E



Property adjacent to the S



Property adjacent to the SW