



Mayor Tab Townsell

City Attorney Michael Murphy

City Clerk/Treasurer Michael O. Garrett

Aldermen

Ward 1 Position 1 – Andy Hawkins
Ward 1 Position 2 – David Grimes
Ward 2 Position 1 – Mark Vaught
Ward 2 Position 2 – Shelley Mehl
Ward 3 Position 1 – Jack Bell
Ward 3 Position 2 – Mary Smith
Ward 4 Position 1 – Theodore Jones, Jr.
Ward 4 Position 2 – Shelia Whitmore

City of Conway

**5:30pm Committee Meeting
Street Projects 2008**

6:30pm -- Council Meeting
Courtroom in District Court Building
810 Parkway, Conway, AR 72034
February 12th, 2008

1. **Call to Order**
2. **Roll Call**
3. **Minutes:** January 22nd, 2008 & February 5th, 2008
4. **Recognition of Guests:**
5. **Public Hearings:**

A. Public hearing to discuss the issuance of bond for Hendrix College.

1. Resolution approving the issuance of capital improvement bonds (Hendrix College Projects).

6. Report of Standing Committees:

A. Community Development Committee (Planning, Zoning, Permits, Community Development, Historic District, Streets, & Conway Housing Authority)

1. Consideration of approval to proceed with bids for the “clean up” of property located at 1470 Wildflower Street.
2. Consideration of using prepaid impact fee from the “Greens at Nutter Chapel” to improve Salem Road.
3. Consideration of bids for Salem Road sidewalk improvements (Saddletop Center to Carl Stuart) for the Conway Street Department.
4. Consideration to grant a franchise to Doe’s Eat Place /Old Chicago Pizza for supporting equipment to be placed in the alley immediately west of the Old Steel Chevrolet Building.
5. Consideration of entering into an agreement with FTN Associates for map corrections involving the floodplain/floodway on a portion of Tucker Creek.

B. Public Service Committee (Sanitation, Parks & Recreation, & Physical Plant)

1. Consideration of bids for the purchase of full size pickup truck with hitch, full size ½ ton pickup truck, and a ¾ ton heavy duty pickup truck for the Physical Plant.
2. Consideration to accept bids on the demolition of properties located on 917 & 1001 Siebenmorgan for the Girls Softball Complex.
3. Discussion of the “unauthorized” boat docks/pier on Lake Beaverfork.
4. Consideration of bids for a 2008 Commercial Rear Load Refuse Truck for the Sanitation Department.
5. Consideration of bids for a 2008 11 yard Commercial rear load refuse truck for the Sanitation Department.
6. Consideration of the reclassification all employees in a CDL position with similar job responsibilities to the same pay grade.

C. Public Safety Committee (Police, CEOC, Fire, Dist. Court & City Att., & Animal Control)

1. Ordinance waiving bids for the purchase of a fire extinguisher training system for the Conway Fire Department.
2. Ordinance amending Ordinance (O-07-108) that clarifies procedures and permit requirements and provides for third party review of fire code requirements for building construction or alteration for the Conway Fire Department.
3. Ordinance accepting insurance proceeds for a damage vehicle from the Arkansas Municipal League for the Conway Police Department.
4. Ordinance appropriating funds to the Conway Police Department for building repairs.
5. Consideration of bids for uniforms for the Conway Police Department.

7. Old Business

8. New Business

Adjournment

CITY OF CONWAY
STREET DEPARTMENT
2008 EXISTING AND PROPOSED STREET PROJECTS
February 6, 2008

Committee Meeting

ESTIMATED STREET FUND BALANCE @ END 2007

\$ 1,500,000

	ORIGINAL AMOUNT	WARD 1	WARD 2	WARD 3	WARD 4
A APPROVED & FUNDED PROJECTS FROM PRIOR YEARS:					
1 College - Salem Int. Add W.B. Rt Turn on College @ Salem (city forces)	\$ 35,000			\$ 35,000	
2 Country Club Ln. - Stermer to Dave Ward (city forces) (funding deferred 3/27/07)	\$ -	\$ -			
3 Golden Meadows Creek Channelization (funding deferred 3/27/07)	\$ -			\$ -	
4 Summerbrook Outfall Drainage Channel (funding deferred 3/27/07)	\$ -			\$ -	
5 Richland Hills Dr. Paving - Hilton to Richland Hills Dr.	\$ 30,000	\$ -			\$ 30,000
6 Richland Hills Dr. New Culvert Under Richland Hills Dr.	\$ 8,176				\$ -
7 Blaney Hill Road - Stone Rd. to City limits	\$ 160,000		\$ 160,000		
8 Street Department Building Addition	\$ 20,172				
9 Software for Traffic Signal Master Controller Software	\$ 151,980				
TOTAL CARRIED OVER STREET CONSTRUCTION PROJECTS	\$ 405,328	\$ -	\$ -	\$ 35,000	\$ 30,000
B CARTS FUNDED PROJECTS (City's 20% - Federal 80% Match):					
2 Western Loop Engineering Study - 20% Match	\$ 1,000	\$ 5,000		\$ 5,000	
3 Salem Road Railroad Overpass (2010+) (\$3,800,000)	\$ -				
4 Harkrider Improvements thru Hendrix College - 20% Match (\$4,700,000) (funding increased 3/27/07)	\$ 760,000		\$ 760,000		
TOTAL CARRIED OVER CARTS PROJECTS	\$ 761,000	\$ 5,000	\$ 760,000	\$ 5,000	\$ -
TOTAL CARRIED OVER PROJECTS ALREADY INCLUDED IN BUDGET		\$ 1,166,328			
ESTIMATED STREET FUND BALANCE PRIOR TO 2008 REVENUE OR EXPENSES		\$ 333,672			

		WARD 1	WARD 2	WARD 3	WARD 4
C STREET AND DRAINAGE PROJECTS APPROVED BY CITY COUNCIL BUT NOT FUNDED FROM STREET FUND:					
1 MAYOR LN. / 286 Traffic Signal (EAST INDUSTRIAL PARK ACCESS ROAD)	\$ 231,435				\$ 231,435
2 FAVRE LANE - ELLEN SMITH TO SALEM -24' ASPHALT W/ DITCH (IMPACT FEE)	\$ 549,236	\$ 549,236			
3 TYLER ST. - EVE LN TO WILLOW RUN SUB. - 36' CURBED TO FILL IN GAPS (IMPACT FEE)	\$ 836,935			\$ 836,935	
4 MUSEUM RD. - SIEB. TO LOWER RDG- 36' Curbed To C. W. - 30' open shoulder to L. R. (IMPACT FEE)	\$ 1,242,198		\$ 1,242,198		
5 SALEM ROAD - MEADOWLAKE TO U.S 64 @ NEW INTERCHANGE - 36' CURBED (SALES TAX)	\$ 2,746,865		\$ 2,746,865		
6 MEADOWS TECHNOLOGY PARK - STREETS & DRAINAGE - (IND. DEVELOPMENT. BONDS)	\$ 176,000				\$ 2,400,000
	\$ 5,782,669	\$ 549,236	\$ 3,989,063	\$ 836,935	\$ 2,631,435

D 2008 STREET FUND BUDGET					
ESTIMATED STREET FUND REVENUE FOR 2007					
State Fuel Tax Turn Back	\$ 2,500,000				
Property Tax (50% 3 mil co. road tax)	\$ 957,488				
Sales Tax (St. Fund Share of Salary Tax)	\$ 200,000				
Conway Corp Franchise Fee	\$ 140,000				
Misc. (Interest, signs & other)	\$ 27,400				
TOTAL ESTIMATED REVENUE FOR 2007		\$ 3,824,888			
1 BUDGETED PERSONAL SERVICES COST	\$ 2,132,000				
2 BUDGETED OPERATING COST (Patching & Construction Material, Fuel, Equip. maint., Etc)	\$ 861,834				
3 PROFESSIONAL SERVICES	\$ 25,000				
4 TRAFFIC SIGNAL MAINTENANCE	\$ 150,000				
5 TRAFFIC SIGNAL CAPITAL COST - LED	\$ 30,000				
7 EQUIPMENT - (Skid Steers & Pickup)	\$ 134,000				
8 SOFTWARE	\$ 15,000				
9 ALLOWANCE FOR STREET OVERLAYS & STREET RECONSTRUCTION	\$ 473,000				
TOTAL SALARIES AND USUAL OPERATING COST		\$ 3,820,834			

E POSSIBLE STREET OVERLAYS & PROJECTS for 2008

STREET	LIMITS of OVERLAY	CITY FORCES	CONTRACTOR EST. COST	WARD 1	WARD 2	WARD 3	WARD 4
1	ROUNDAABOUT @ Farris & Bruce		\$ 80,000	\$ 180,000			
2	DONAGHEY Washington to Meadowlake	2400' - overlay	\$ 62,000		\$ 62,000		
3	EXCHANGE AVE Dave Ward to Commerce	1670' - overlay	\$ 30,000	\$ 30,000			
4	EXCHANGE AVE Commerce to Runway Dr.	3020' - overlay	\$ 55,000	\$ 55,000			
5	COMMERCE ST. Exchange to Harkrider	3250' - overlay	\$ 58,000	\$ 58,000			
6	MIDDLE ROAD E. German TO Skunk Hollow - 50% Paving w/ county forces		\$ 62,500				\$ 62,500
7	LOWER RIDGE RD Victory Lane thru East German - 50% Paving w/ county forces		\$ 33,000		\$ 33,000		
8	BILL LUCY Trison to E. German		\$ 24,000		\$ 24,000		
9	OAK St. Street Scape Chestnut to Van Ronkle		\$ 78,834		\$ 39,417		\$ 39,417
SUBTOTAL			\$ 483,334				
10	MIDDLE ROAD Amity to Southland	2000' 36' curbed	\$ 232,000				\$ 467,000
11	MIDDLE ROAD Southland to E. German	1800' - 36' curbed	\$ 253,000				\$ 488,000
12	FACTORY ST. Oak St. to Mill St.	1230' reconstruct to 27' curbed	\$ 100,000		\$ 200,000		
13	SHAMROCK	1600' - overlay	\$ 24,000	\$ 24,000			
14	OAKLAWN	1900' - overlay	\$ 28,000	\$ 28,000			
15	STANLEY RUSS Sturgis to Top of Hill	3200' 24' asphalt w/ open ditch	\$ 272,000				\$ 560,000
16	BLANEY HILL ROAD HWY 25 to Stone Rd.	3600'	\$ 240,000		\$ 200,000		
17	GRIFFIN STREET Bruce to McKay	630' 27' curbed	\$ 55,000				\$ 120,000
18	DEERBROOK Nutter Chapel to Old Military (24' Pavement w/open ditch)		\$ 93,000	\$ 200,000			
19	SOUTH SALEM Nutter Chapel to the Greens PUD (Rebuild to 36' curb & gutter)		\$ 370,000	\$ 839,850			
20	TJ Gertrude to Oak Meadows	overlay	\$ 27,000	\$ 27,000			
21	HOGAN LN. Tyler to U.S. 64	overlay	\$ 84,000			\$ 84,000	
22	QUAIL RUN add gravel, shape ditches & overlay		\$ 50,000	\$ 50,000			
23	SHERMAN OAKS South of Prince & East of Country Club		\$ 33,000			\$ 33,000	
24	STONECREST Stonewood - Garden Walk	overlay	\$ 16,000	\$ 16,000			
25	CROSS POINT Stonewood - Silvercrest	overlay	\$ 16,000	\$ 16,000			
26	RICHLAND HILLS DR. All south of Richland Hills Cv. Rebuild about 30%-overlay rest.		\$ 75,000				\$ 75,000
27	MILL POND ROAD Ginger Kerry to 321 (Chip & Seal by County)		\$ 29,000				\$ 29,000
28	MILL POND ROAD 321 tp Pauls Ln. (Chip & Seal by County)		\$ 67,000				\$ 67,000
29	EAST GERMAN LANE Widen for Left Turn Lane @ Conway Christian School		\$ 20,000	\$ 50,000			\$ 50,000
30	MORNINGSIDE DR. Timberlane Trail to Tucker Creek (should be rebuilt)		\$ 43,000			\$ 43,000	
TOTAL STREET OVERLAY & PROJECTS FOR 2007			\$ 2,610,334	\$ 3,751,332	\$ 1,543,850	\$ 558,417	\$ 1,957,917

F CORRIDOR PROJECTS

SUGGESTED 2008 PROJECTS - Funded from Sales Tax

STREET	LIMITS of PROJECT		
SALEM ROAD EXTENSION	Meadowlake to Hwy 64 @ New Interchange	\$ 2,746,865	\$ 2,600,000
COLLEGE AVENUE (5 - Lanes)	Salem to Hubbard	\$ 750,000	\$ 640,000
COLLEGE AVE - COUNTRY CLUB	Intersection Improvemets - Possible Roundabout	\$ 400,000	\$ 750,000
SALEM ROAD	Nutter Chapel to Greens PUD (Add. Needed to Supplement \$700,000 IMPACT FEE)	\$ 139,850	\$ 1,070,000
Subtotal 2008 Projects		\$ 4,036,715	

NEAR FUTURE PROJECTS

DONAGHEY AVENUE - DAVE WARD DRIVE INTERSECTION (RT. Turn + Dual Left)	\$ 600,000
PRINCE STREET - SALEM ROAD INTERSECTION	\$ 600,000
FARRIS - PRINCE INTERSECTION (Possible Roundabout)	\$ 300,000
FARRIS ROAD IMPROVEMENT Dave Ward Drive to Bruce Street (36' Curbed Street)	\$ 660,000
PRINCE STREET - Salem to Western (Four Lanes with left turn lane were required)	\$ 2,200,000
College Avenue - Hubbard to Donaghey	\$ 2,750,000
Subtotal Near Future Projects	\$ 7,110,000

MEMORANDUM

TO: MAYOR TAB TOWNSELL

FROM: RONNIE HALL, P.E.
CITY ENGINEER

DATE: February 6, 2008

REFERENCE: 2008 Street Projects

The Street Department work crews are scheduled to complete the following 2007 Street Projects by the end of March 2008:

1. **Blaney Hill Road** - Reconstruct road to 24' asphalt w/ 6' gravel shoulders from Stone Road to Skinner Hill Rd with overlay of exist pavement to western city limits.
2. **Richland Hills Road Overlay** - Hilton Dr. to Richland Hills Cove.
3. **Siebenmorgen-Courtway-Freyaldenhoven Roundabout** - Construct new box culvert (3 barrels 12' x 5' box culvert) under Siebenmorgen Road & complete west leg of Roundabout.

Following this work they will be available to begin a new project. It would help us if the street overlay list could be finalized soon allowing us to perform the preparation work for the overlays during the wet winter and spring months and make more staff available for street projects during the summer.

2008 STREET FUND PROJECTS

I have attached a summary sheet listing several street overlay and street reconstruction projects. Our budget includes \$473,000 for street overlays and reconstruction. The following projects in my opinion need to be funded to properly address the maintenance of the street infrastructure:

1. **Farris - Bruce Roundabout** - \$80,000 - The existing four way stop at this location backs up several blocks during peak hour traffic. The roundabout should allow traffic to move freely thru this intersection.
2. **Donaghey Street Overlay** - Washington to Meadowlake - \$62,000
The existing pavement along this section of street is failing as can be seen by the cracking section of asphalt and the depressions developing along the vehicle wheel path. The heavy volume of traffic will destroy the integrity of the existing pavement if the street is not repaved soon. The strength and durability of the street is dependent on the thickness of sound asphalt pavement. If the pavement is allowed to deteriorate we will lose the strength the existing asphalt pavement provides.
3. **Exchange Avenue Overlay** - Dave Ward to Runway - \$85,000
Heavy industrial loads are causing the failure of the pavement along Exchange Ave. As described above, the overlay

is needed before the existing pavement section deteriorates further. The repairs of this road would give a more favorable impression to the current and potential industrial residents regarding the city's commitment to maintain the access to their facilities.

4. **Commerce Street Overlay** - Exchange to Harkrider - \$58,000 - As described above heavy industrial loads are causing the failure and is needed before the existing pavement section deteriorates further. The repairs of this road would give a more favorable impression to the current and potential industrial residents regarding the city's commitment to maintain the access to their facilities.
5. **OAK ST. STREETScape** - Chestnut to Court - \$78,834 - This project would continue the sidewalk improvements along Oak street eastward to Court Street. The cost presented does not address any drainage or flooding issues. City crews would perform the work (market value of \$167,648) with the estimated cost of \$78,834 for materials and outside contractors only. Asphalt paving of this section of street is included in the estimate.
6. **Joint County/City Projects** - County Judge Preston Scroggins has offered to joint venture the improvement of three roads that are generally 50% in the county and 50% in the city. The Judge has offer to perform the repairs to the subgrade and placement of crushed stone base course and pay for 50% of the asphalt paving on the following roads:
 1. **Lower Ridge Road** - Victory Ln. thru East German Ln. (2,600 feet) - 50% of the asphalt cost is \$33,000
 2. **Bill Lucy Dr.** - along north side Simon School (2,600 feet) - 50% of the asphalt cost is \$24,000
 3. **Middle Road** - East German Lane to Skunk Hollow Road - (5,000 feet) - 50% of asphalt cost is \$62,500These roads are in poor condition and certainly need attention. This gives us an opportunity to gets these streets improved at minimal cost.

IMPACT FEE & CARTS FUNDED PROJECTS

The following projects are presently programmed for funding from non street fund sources:

1. **Harkrider** - Fleming to Spruce - Four lane median divided roadway with 208' diameter roundabouts at Siebenmorgen and at Winfield. The project also includes a pedestrian underpass on the north side of Siebenmorgen Road. This project is estimated to cost \$4,600,000 with 80% federal funding thru Metroplan and 20% local match. The AHTD is presently acquiring ROW for this project. The relocation of a 16" waterline must be completed before this project can get underway. It is estimated that the waterline relocation will not be completed until late fall.
2. **Tyler Street** - Eve Lane to Willow Wind Subdivision - 36' curbed street with sidewalk on south side. \$836.935 - Funded with street impact fees. Bid opening in February

3. **Salem Road** - Nutter Chapel Rd. to north boundary of the "Greens @ Nutter Chapel PUD". This project is needed to prevent the further destruction of the pavement along this section of Salem or along Nutter Chapel Rd by the "Greens" construction traffic. This section of road has already been damaged by the construction traffic to the Subdivision along South Salem. The improved road will provide an appropriate western connection to the Favre Lane Project for access to Ellen Smith School and the subdivision along South Salem (Southwind, Spring Valley & Bradley Place) - The estimated cost of a 36 foot curbed street with sidewalk on one side is \$839,850. Possible funding for this project could be Prepayment of the "Greens" impact fee (\$700,000) supplemented with revenue from Sales Tax.
4. **Museum Road** - Siebenmorgen Road to Lower Ridge Road - (1,543,959) Bid opening in late Fall (waiting on adequate accumulation of Street Impact Fee)

SALES TAX - CORRIDOR IMPROVEMENT PROJECTS

Revenue from the 50% of the ½ cent sales tax is now accumulating for major street projects. The initial project approved for funding from this revenue is **Salem Road** - Meadowlake Rd. to U.S. 64 at the new I-40 interchange. The estimated cost for a 36' curbed street with sidewalk on one side is \$2,746,765. The plans are being prepared now and Right of Way acquisition needs to be completed in February so that we can open bids in early March.

Funds will be available for other corridor improvement projects by mid year. It would be desirable to proceed with the plans for the next projects in order to give the utility companies time to adjust or relocate their facilities and us time to get any right of way issues resolved.

If we focus on improvement of the intersections, we can have a significant impact on improvement of traffic flow without undertaking the major street reconstruction. Projects that would reduce congestion by adding lanes at intersection included the following:

1. College Avenue - Salem to Hubbard (5-Lanes) (\$750,000)
2. College Avenue - Country Club Road - Possible Roundabout (\$400,000)
3. Donaghey Ave at Dave Ward - (Rt. Turn Lane + Dual Left on Donaghey)
4. Prince - Salem Intersection (add Rt. Turn Lane)
5. Farris Road - Dave Ward to Bruce
6. Salem Road - Dave Ward to College
7. College Ave - Hubbard to Donaghey
8. Prince - Salem to Western



**City of Conway, Arkansas
Resolution No. R-08-_____**

A RESOLUTION APPROVING THE ISSUANCE OF PUBLIC FACILITIES BOARD OF THE CITY OF CONWAY, ARKANSAS CAPITAL IMPROVEMENT REVENUE BONDS (HENDRIX COLLEGE PROJECTS), IN ONE OR MORE SERIES, BY THE PUBLIC FACILITIES BOARD OF THE CITY OF CONWAY, ARKANSAS; PRESCRIBING OTHER MATTERS RELATING THERETO; AND DECLARING AN EMERGENCY.

WHEREAS, Hendrix College (the “College”) has requested that the City of Conway, Arkansas Public Facilities Board (the “Board”) issue Capital Improvement Revenue Bonds in an aggregate principal amount of approximately \$37,500,000 (the “Bonds”); and

WHEREAS, the Board is authorized pursuant to the Public Facilities Board Act, Ark. Code Ann. §§ 14-137-101 to 123 (1998 Repl.; 2007 Suppl.) to issue bonds to finance educational facilities within the City of Conway; and

WHEREAS, following a public hearing before the City Council for which notice has been given in the manner required by Ark. Code Ann. § 19-9-607, the City Council has determined that the public purposes for which the Bonds are to be issued serve a proper need; and

WHEREAS, the City Council of the City of Conway, Arkansas (the “City”) desires to acknowledge its approval of the College’s request and the issuance of the Bonds by the Board after adoption of appropriate resolutions by the Board.

NOW, THEREFORE, be it resolved by the City Council of the City of Conway, Arkansas:

Section 1. That the issuance of the bonds by the Board in an aggregate principal amount of approximately \$37,500,000 for the purposes of financing the acquisition, construction and equipping of certain capital improvements at Hendrix College is hereby authorized. The proposed capital improvements are expected to consist primarily of (i) a portion of the cost of a building and equipping a Student Life and Technology Center, (ii) campus wide HVAC improvements, (iii) other improvements, acquisitions, fixtures and equipment incidental to (i) and (ii), and (iv) for such other capital improvements as may be requested by the College and approved by the Board (all of which are hereinafter referred to as the “Improvements”).

Section 2. That this resolution is adopted for the purpose of complying with the requirements of Ark. Code Ann. § 19-9-601, et seq.

Section 3. That the provisions of this resolution are hereby declared to be separable and if any provision shall for any reason be held illegal or invalid, such holdings shall not affect the validity of the remainder of this resolution.

Section 4. The need to provide facilities for the continued growth and development of Hendrix College being necessary for the preservation of the public peace, health, safety, and welfare, an emergency is hereby declared and this resolution shall be in full force and effect from and after its passage.

PASSED AND APPROVED this 12th day of February, 2008.

Tab Townsell, Mayor

ATTEST:

Michael O. Garrett
City Clerk/Treasurer

6A-1

**City of Conway
Code Enforcement
1201 Oak Street
Conway, AR 72032**



February 1, 2008

Mayor Tab Townsell &
Council Members
Conway, AR 72032

Dear Council Members:

We would like to request to bid out the clean up of property located at 1470 Wildflower Street. The unfinished house is under foreclosure and the owner has been asked on several occasions to bring the property up to city code, which has not been done.

Therefore, we will like to proceed to go to bid to get the property brought up to City code. Please see the attached pictures of what has been left on this property.

Thank you
Barbara McElroy

Complaint

Person Calling:

N/A

Date:

10/18/17

Address:

Phone:

Location of Complaint:

1470 Wildflower

Nature of Complaint:

Pile of brush in yard
been sitting for a year

Taken by:

Pom

Department Response:

Warning # CE 4270

Date:

10-19-07

Time:

1218

Signature
Confirmation # 91 3408 2133 3931 2464 0484

NO CE4270

WARNING
To Correct Violation

Conway Code Enforcement Notice of Violation
1201 Oak Street
Conway, AR 72032
501-450-6191

Name Jamm Construction
Address 1470 Wildflower
City Conway ST Ar Zip 72034

- 0-01-63 Rubbish, Trash, Unsanitary Matter
- 0-04-95 Grass Ordinance
- 0-01-63 Stagnant Water Ordinance
- 0-01-63 Illegal Dumping Ordinance
- 0-04-54 Appliance/Furniture Ordinance
- 0-96-78 Trash Can Ordinance
- 0-04-53 Abandoned/Inoperable Vehicle Ordinance
- 0-420 Dilapidated Structure Ordinance
- 0-94-54 Recreational/Commercial Vehicle Ordinance
- 0-94-54 Trailer Ordinance
- 0-03-89 Street Address Ordinance
- 0-02-53 Sediment on Road Ordinance
- 0-96-60 Sign Ordinance

*clean up
construction
site &
remove
large
brush/
debris
pile in
back yard*

Other _____

Dated this 19th day of October, 2007

Grant Tomlin

Signature of Code Enforcement Officer

**CORRECTIONS MUST BE MADE
WITHIN SEVEN DAYS OF VIOLATION**

I promise to take the necessary actions to remedy the violation noted above into compliance with the City of Conway Code Enforcement Code. I understand that failure to comply by the date stated above will result in a citation to appear in the Municipal Court of the City of Conway.

CITY OF CONWAY
Code Enforcement
1201 Oak Street
Conway, Arkansas 72032



Grant Tomlin
Code Enforcement Officer
Barbara McElroy
Code Enforcement Assistant
Phone 501-450-6191
Fax 501-513-3504

October 30, 2007

Michael Fosler
DBA Jamm Construction
1016 Highland Blvd
Cabot, AR 72023

Dear Mr. Fosler,

I am writing to you in reference to the condition of the property located on 1470 Wildflower Street in the City of Conway, Arkansas. There have been complaints in reference to the property and upon inspection; I found that there is a code violation concerning the condition of the property.

Ordinance No. 0-01-63 states that rubbish, brush, trash, scrap metal, inoperable machinery, dead trees, building materials or unsanitary matter of whatever nature to accumulate or be present upon any lot, tract or parcel of land. Construction site must be cleaned up and the pile of brush/debris in back yard must be picked up.

Ordinance 0-2001-63 authorizes the city to abate nuisances and to place liens on property found to be non-complaint. Upon receipt of written notice the owner can be fined up to \$250.00 per day and a citation issued for failure to comply. The cost of grass cutting and debris removal will be billed to the property owner. If the owner refuses to pay the bill then a lien may be filed on the property for all associated costs for the property maintenance.

NOTE: THIS WILL BE THE ONLY CERTIFIED NOTIFICATION THAT YOU WILL RECEIVE THIS SEASON REGARDING THIS PROPERTY.

If you have any questions, please don't hesitate to call 501-450-6191.

Sincerely,

Grant Tomlin
Code Enforcement Officer

CITY OF CONWAY
Code Enforcement
1201 Oak Street
Conway, Arkansas 72032



Grant Tomlin
Code Enforcement Officer
Barbara McElroy
Code Enforcement Assistant
Phone 501-450-6191
Fax 501-513-3504

November 14, 2007

Jamm Construction
Michale Fosler
1016 Highland Blvd
Cabot, AR 72023

Dear Mr. Fosler,

I am writing to you in reference to the condition of the property located at 1470 Wildflower Street in the City of Conway, Arkansas. There have been complaints in reference to the property and upon inspection; I found that there is a code violation concerning the condition of the property.

Ordinance No. 0-01-63 states that rubbish, brush, trash, scrap metal, inoperable machinery, dead trees, building materials or unsanitary matter of whatever nature to accumulate or be present upon any lot, tract or parcel of land.

Ordinance 0-2001-63 authorizes the city to abate nuisances and to place liens on property found to be non-complaint. Upon receipt of written notice the owner can be fined up to \$250.00 per day and a citation issued for failure to comply. The cost of grass cutting and debris removal will be billed to the property owner. If the owner refuses to pay the bill then a lien may be filed on the property for all associated costs for the property maintenance.

NOTE: THIS WILL BE THE ONLY CERTIFIED NOTIFICATION THAT YOU WILL RECEIVE THIS SEASON REGARDING THIS PROPERTY.

If you have any questions, please don't hesitate to call 501-450-6191.

Sincerely,

Grant Tomlin
Code Enforcement Officer

MEMORANDUM

6A-2

TO: MAYOR TAB TOWNSELL

FROM: RONNIE HALL, P.E.
CITY ENGINEER

DATE: January 29, 2008

REFERENCE: Salem Road Reconstruction & Extension to Greens @
Nutter Chapel PUD

In order to improve to the access to the Greens at Nutter Chapel PUD, Rush-Hal has offered to make available to the city immediately for the improvement of Salem Road the street impact fee that would be required of their project. The impact fee for the 900 apartments would total \$693,900 (\$771/unit x 900 units).

Our preliminary estimate is \$839,350 for improving the 3,900 feet of Salem Road from Nutter Chapel Road to the north boundary of the PUD. The improvements would provide a 36 foot curbed street with sidewalk on one side.

If we do not improve either Salem or Nutter Chapel, the construction traffic associated with the 900 apartments will likely destroy the pavement on these roads.

In order to get Salem completed in time to accommodate the construction traffic we need to get the project started immediately.

To get this project moving we need approval to allow the prepayment of the street impact fee and allow that money to be spent on Salem Road. We also need authorization to proceed with the Salem Road Improvement project.



CITY OF CONWAY
STREET AND ENGINEERING DEPT.

100 East Robins • Conway, AR 72032
501-450-6165 • Fax 501-513-3566

Ronnie D. Hall, P.E.
City Engineer

6A-3

February 5, 2008

Mayor Tab Townsell
City Hall
1201 Oak Street
Conway, Arkansas 72032

Re: Salem Road Sidewalk Improvements
Saddletop Center to Carl Stuart

Dear Mayor Townsell,

Bids were received at 10:00 AM, Tuesday February 5, 2008 at Conway City Hall for the above referenced project. This project involves the construction of 1,400 feet of sidewalk and related retaining wall work along the east side of Salem Road from Lindsey Street to Carl Stuart Street. Five bids were received for this work as summarized below and detailed on the attached Tabulation of Bids.

HoJo Excavating, Inc.	\$99,640.90
Paladino Construction	\$121,095.00
Paladino-Nash, Inc.	\$179,601.75
F.P. Bivens Construction Co.	\$180,327.50
Township Builders	\$255,558.00
Engineer's Estimate	\$150,000.00

The bid submitted by HoJo Excavating contained several errors in the extension of the unit price to total amount in Bid Items No. 4, 5, 6, 7, & 8. The Bid Amount was read as \$75,108.04. With the errors corrected the Total Bid Amount is \$99,640.90. The most significant change was Item No 4 which was listed on the bid form as \$2,726.90 and correctly multiplied should be \$27,269.00. This bid appears to be a fair and reasonable bid for the work involved. I recommend that this project be awarded to the low bidder HoJo Excavation Inc.

Since no funding has been established for this project, the funding issue needs to be addressed.

Please advise if you have questions or need additional information.

Sincerely,

Ronnie Hall, P.E.

CITY OF CONWAY
SALEM ROAD SIDEWALK IMPROVEMENTS
SADDLETOP CENTER TO CARL STUART

TABULATION OF BIDS RECEIVED FEBRUARY 5, 2008, 10:00 A.M.

ITEM	DESCRIPTION	ESTIMATED QUANTITY	UNITS	HOJO CONSTRUCTION		PALADINO CONSTRUCTION		PALADINO-NASH, INC.	
				UNIT PRICE	AMOUNT	UNIT PRICE	AMOUNT	UNIT PRICE	AMOUNT
1	SITE PREPARATION	1	L.S.	\$ 4,625.00	\$ 4,625.00	\$ 1,500.00	\$ 1,500.00	\$ 2,000.00	\$ 2,000.00
2	UNCLASSIFIED EXCAVATION	100	C.Y.	\$ 15.50	\$ 1,550.00	\$ 10.00	\$ 1,000.00	\$ 9.90	\$ 990.00
3	EMBANKMENT	240	C.Y.	\$ 11.00	\$ 2,640.00	\$ 9.00	\$ 2,160.00	\$ 7.85	\$ 1,884.00
4	CRUSHED STONE BASE	2,035	TON	\$ 13.40	\$ 27,269.00	\$ 11.00	\$ 22,385.00	\$ 16.40	\$ 33,374.00
5	MODULAR BLOCK WALL	2,060	S.F.	\$ 8.74	\$ 18,004.40	\$ 16.00	\$ 32,960.00	\$ 21.95	\$ 45,217.00
6	HAND RAILING	670	L.F.	\$ 17.55	\$ 11,758.50	\$ 19.50	\$ 13,065.00	\$ 27.40	\$ 18,358.00
7	CONCRETE SIDEWALK	745	S.Y.	\$ 19.30	\$ 14,378.50	\$ 42.00	\$ 31,290.00	\$ 44.75	\$ 33,338.75
8	HANDICAP RAMP	250	S.F.	\$ 8.59	\$ 2,147.50	\$ 8.50	\$ 2,125.00	\$ 24.50	\$ 6,125.00
9	DROP INLET	1	EA.	\$ 1,865.00	\$ 1,865.00	\$ 2,300.00	\$ 2,300.00	\$ 2,900.00	\$ 2,900.00
10	DROP INLET ON EXISTING BOX	3	EA.	\$ 725.00	\$ 2,175.00	\$ 1,231.00	\$ 3,693.00	\$ 2,900.00	\$ 8,700.00
11	SEEDING	1	AC.	\$ 5,240.00	\$ 5,240.00	\$ 2,400.00	\$ 2,400.00	\$ 1,500.00	\$ 1,500.00
12	SILT FENCE	1,000	L.F.	\$ 3.00	\$ 3,000.00	\$ 2.00	\$ 2,000.00	\$ 2.90	\$ 2,900.00
13	BALED STRAW	36	BALE	\$ 8.00	\$ 288.00	\$ 6.00	\$ 216.00	\$ 9.00	\$ 324.00
14	CONSTRUCTION LAYOUT	1	L.S.	\$ 1,900.00	\$ 1,900.00	\$ 4,000.00	\$ 4,000.00	\$ 13,000.00	\$ 13,000.00
15	TRENCH & EXCAVATION SAFETY	1	L.S.	\$ 2,800.00	\$ 2,800.00	\$ 1.00	\$ 1.00	\$ 8,991.00	\$ 8,991.00
TOTAL AMOUNT BID					\$ 99,640.90		\$ 121,095.00		\$ 179,601.75

ITEM	DESCRIPTION	ESTIMATED QUANTITY	UNITS	F. P. BIVENS		TOWNSHIP BUILDERS		ENGINEER'S ESTIMATE	
				UNIT PRICE	AMOUNT	UNIT PRICE	AMOUNT	UNIT PRICE	AMOUNT
1	SITE PREPARATION	1	L.S.	\$ 2,100.00	\$ 2,100.00	\$ 39,379.00	\$ 39,379.00	\$ 5,000.00	\$ 5,000.00
2	UNCLASSIFIED EXCAVATION	100	C.Y.	\$ 10.00	\$ 1,000.00	\$ 13.00	\$ 1,300.00	\$ 25.00	\$ 2,500.00
3	EMBANKMENT	240	C.Y.	\$ 8.00	\$ 1,920.00	\$ 18.00	\$ 4,320.00	\$ 20.00	\$ 4,800.00
4	CRUSHED STONE BASE	2,035	TON	\$ 16.50	\$ 33,577.50	\$ 23.00	\$ 46,805.00	\$ 12.00	\$ 24,420.00
5	MODULAR BLOCK WALL	2,060	S.F.	\$ 22.00	\$ 45,320.00	\$ 25.00	\$ 51,500.00	\$ 25.00	\$ 51,500.00
6	HAND RAILING	670	L.F.	\$ 27.50	\$ 18,425.00	\$ 85.00	\$ 56,950.00	\$ 25.00	\$ 16,750.00
7	CONCRETE SIDEWALK	745	S.Y.	\$ 45.00	\$ 33,525.00	\$ 40.00	\$ 29,800.00	\$ 36.00	\$ 26,820.00
8	HANDICAP RAMP	250	S.F.	\$ 25.00	\$ 6,250.00	\$ 16.00	\$ 4,000.00	\$ 5.00	\$ 1,250.00
9	DROP INLET	1	EA.	\$ 2,500.00	\$ 2,500.00	\$ 2,400.00	\$ 2,400.00	\$ 1,500.00	\$ 1,500.00
10	DROP INLET ON EXISTING BOX	3	EA.	\$ 3,000.00	\$ 9,000.00	\$ 1,200.00	\$ 3,600.00	\$ 2,000.00	\$ 6,000.00
11	SEEDING	1	AC.	\$ 1,850.00	\$ 1,850.00	\$ 11,000.00	\$ 11,000.00	\$ 2,000.00	\$ 2,000.00
12	SILT FENCE	1,000	L.F.	\$ 3.00	\$ 3,000.00	\$ 3.00	\$ 3,000.00	\$ 4.00	\$ 4,000.00
13	BALED STRAW	36	BALE	\$ 10.00	\$ 360.00	\$ 14.00	\$ 504.00	\$ 10.00	\$ 360.00
14	CONSTRUCTION LAYOUT	1	L.S.	\$ 12,500.00	\$ 12,500.00	\$ 700.00	\$ 700.00	\$ 3,000.00	\$ 3,000.00
15	TRENCH & EXCAVATION SAFETY	1	L.S.	\$ 9,000.00	\$ 9,000.00	\$ 300.00	\$ 300.00	\$ 100.00	\$ 100.00
TOTAL AMOUNT BID					\$ 180,327.50		\$ 255,558.00		\$ 150,000.00

NORTH SIDE PLUMBING

6A4

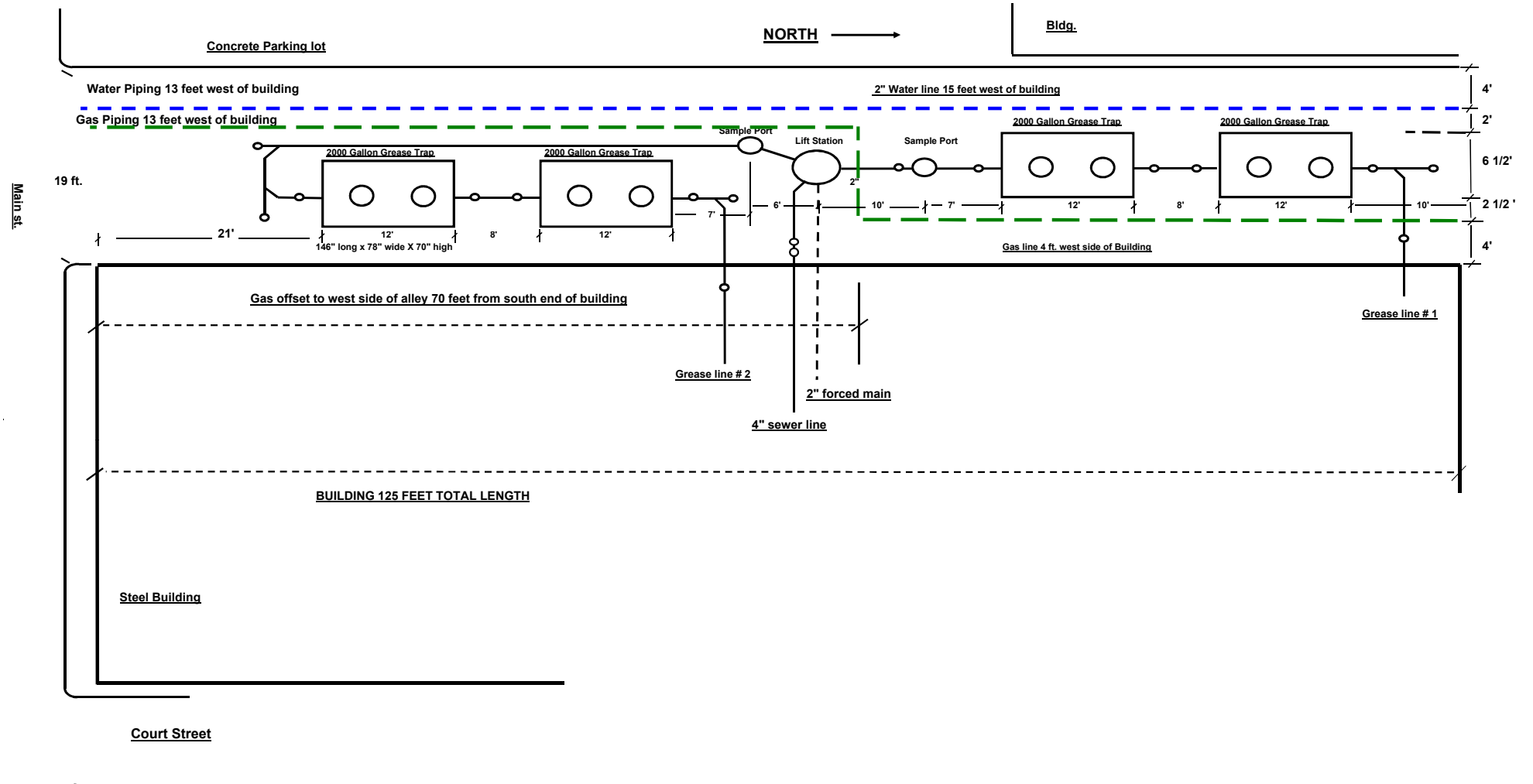

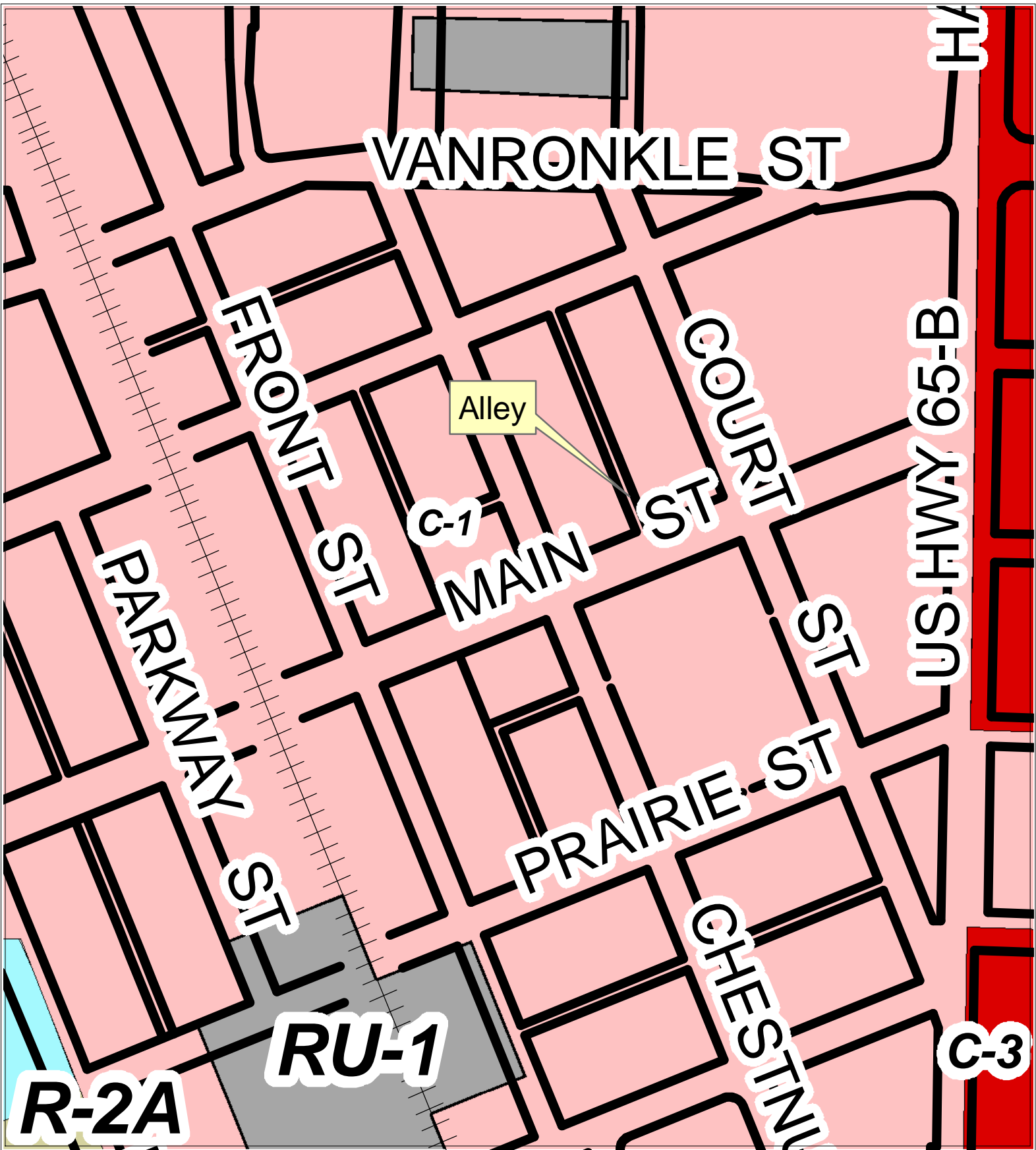

0 80 160 320 480 640 Feet

Chicago Pizza
Does Eat Place
Alley Franchise



124 W Sunbridge Drive, Suite 3 • Fayetteville, AR 72703 • (479) 571-3334 • FAX (479) 571-3338

January 28, 2008

**The Honorable Tab Townsell
Mayor, City of Conway
1201 Oak Street
Conway, Arkansas 72032**

**RE: Preparation of Letter of Map Revision (LOMR) by Map Correction
For Tucker Creek from Hogan Lane to Prince Street
FTN No. P4240-08-01**

Dear Mayor Townsell:

In response to a request made by Mr. Ronnie Hall, City Engineer for Conway, Arkansas (City), we appreciate the opportunity to submit the following proposal to provide consulting services related to floodplain/floodway issues associated with Tucker Creek from Hogan Lane upstream to Prince Street (the Project) as described in Exhibit A.

Our Basic Services will generally consist of evaluation and preparation of the required paper work and map revision by correction necessary for a Letter of Map Revision (LOMR) along the Project area. The City will be responsible for providing topographic and/or photogrammetry data as needed in the Project area. Because this LOMR will be based on a Map Correction as well as being sponsored by the City, no FEMA review fees are expected. Our services are subject to the Standard Terms and Conditions (Exhibit B), which are attached to this letter. We will also furnish any additional services you may request.

Our fee for Basic Services will be based on a lump sum of \$7,500 as outlined in Exhibit A. Any Additional Services requested by you will be charged on the basis of time and materials using the fee schedule provided in Exhibit C.

We will bill you monthly for Services and Reimbursable Expenses with invoices to be paid within 30 days. The above financial arrangements are on the basis of prompt payment of our bills and the orderly and continuous progress of the Project.

If there are protracted delays for reasons beyond our control, we would expect to negotiate with you an equitable adjustment of our compensation taking into consideration the impact of such

Corporate Office: 3 Innwood Circle, Suite 220 • Little Rock, AR 72211 • (501) 225-7779 • Fax (501) 225-6738
Regional Offices: Fayetteville, AR; Baton Rouge, LA; Jackson, MS • www.ftn-assoc.com • ftn@ftn-assoc.com

delays including but not limited to changes in price indices and pay scales applicable to the period when services are in fact being rendered.

This proposal, which includes Exhibits A, B, and C consisting of 6 pages, represents the entire understanding between you and us in respect of the Project and may only be modified in writing signed by both of us. If it satisfactorily sets forth your understanding of our agreement, we would appreciate your indicating the services you would like us to perform and signing the enclosed copy of this letter in the space provided below and returning it to us. This proposal will be open for acceptance until February 29, 2008 unless changed by us in writing.

Thank you very much for the opportunity to present this proposal. Please do not hesitate to call me at 479-571-3334 or Tom Larson, PE, at 501-225-7779 if you have any questions relating to this proposal or additional services offered by FTN.

Respectfully submitted,
FTN ASSOCIATES, LTD.

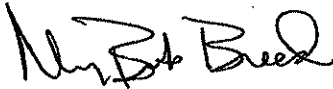

MaryBeth Breed
Hydrologist

MBB/fjm

Attachments

R:\WP_FILES\PROPOSALS\2008\L-T TOWNSELL 01-28-08 CONWAY.DOC

Accepted this _____ day
of _____, 2008

By _____
Authorized Representative



EXHIBIT A
Scope of Work for Basic Services
City of Conway
Tucker Creek LOMR Map Correction

Attached to and made part of the Letter Agreement dated January 28, 2008 between the City of Conway (the Client) and FTN Associates, Ltd. (FTN), in respect to the Project described therein. The objectives, specific tasks, assumptions, and proposed schedule for the Project follow:

Project Objectives

The objectives of the Project are:

1. To compare the location of special flood hazard area subject to inundation by the 1% annual chance flood and the floodway for a portion of Tucker Creek (specifically from Hogan Lane upstream to Prince Street, approximately 2.6 mi) depicted on the current effective Faulkner County FIRM panels 05045C0278H and 05045C0279H, dated December 19, 2006, to work maps provided by FTN to the City of Conway and submitted to FEMA in 2002.
2. To prepare the necessary documentation for a LOMR to incorporate proposed map correction(s) to the FEMA effective panels using the FTN work maps in areas where the work maps provide updated floodplain/floodway locations.

FTN Project Tasks

Specific project tasks are as follows:

1. Obtain Faulkner County, AR DFIRM database and panels from the FEMA project library.
2. Perform comparison of the digital floodplain/floodway on the effective Faulkner County FIRMs and digital data prepared by FTN and submitted to FEMA and the City of Conway (FEMA Contract EMT-2001-CO-0028, Task Order 2, Faulkner County, AR FIS Restudy, 2002).
3. Prepare revisions including updated database based on FTN data.
4. Prepare annotated FIRM panels for submittal to FEMA showing the revisions.
5. Prepare a Letter of Map Revision application to FEMA for a mapping correction in the areas along Tucker Creek where the FTN data provided more accurate floodplain/floodway location based on current conditions and available data.
6. Coordination with the Client and the City of Conway throughout the course of the data review and preparation and submittal of LOMR application to FEMA, including monthly progress reports.

Project Assumptions

1. Any topographic and/or photogrammetry data necessary in the data review will be the data used in the FTN Flood Study submitted in 2002, described above, and provided by the City of Conway if necessary. If the data used previously is not available additional services will be required in order to evaluate the data with different source data.
2. This estimate does not include meetings with the City to discuss or explain the results of the data review and LOMR application for the Project.
3. This estimate does not include performance of any hydrologic or hydraulic analyses related to the effective floodplain/floodway mapping or flooding source.

Proposed Schedule

1. Begin services within one week after receipt of your acceptance of this proposal.
2. Prepare and submit to FEMA the LOMR application within thirty (30) days after receipt of all information needed from the FEMA library and the City of Conway.

EXHIBIT B

**Standard Terms and Conditions
For FTN Contracts**

1. **Standard of Care** The services provided by FTN shall be performed in accordance with generally accepted professional practice at the time when and the place where the services are rendered.
2. **Independent Contractor** FTN is an independent contractor and not an employee or agent of CLIENT. CLIENT is not responsible for any of its activities. Any taxes, licenses, permits, required filing of forms or any other conditions imposed upon or required to render FTN Services shall be satisfied by FTN at FTN's expense.
3. **Insurance** FTN shall procure and maintain insurance for protection from claims under workers' compensation acts. FTN shall procure and maintain liability insurance against claims based on FTN's negligence for damages because of bodily injury including personal injury, sickness or disease or death of any and all employees or of any person other than such employees, and from claims or damages based on FTN's negligence because of injury to or destruction of property including loss of use resulting therefrom.
4. **Indemnification**
 - a. FTN does hereby indemnify and save harmless CLIENT from and against any and all liability and claims of liability of any and every kind and nature, including without limitation bodily injury, death and property damage, arising out of any negligent act by FTN, and FTN, at FTN's sole expense, shall handle all such claims, defend all lawsuits filed against CLIENT therein, and reimburse CLIENT in cash for all reasonable expense incurred by CLIENT on account thereof, provided, that if CLIENT elects to retain independent counsel, FTN shall reimburse CLIENT for all costs reasonably incurred by CLIENT to defend itself through attorneys of CLIENT's choice. There is hereby excepted from the foregoing any and all liability and claims of liability solely attributable to acts of CLIENT's direct payroll employees, and there is hereby further excepted from the foregoing any and all liability and claims of liability for environmental pollution which are not the result of negligence on the part of FTN in FTN's performance of this contract.
 - b. CLIENT does hereby indemnify and save harmless FTN from and against any and all liability and claims of liability of any and every kind and nature including without limitation bodily injury, death, property damage and claims for environmental pollution which are not the result of negligence on the part of FTN in FTN's performance of this contract, and CLIENT, at CLIENT's sole expense, shall handle all such claims, defend all lawsuits filed against FTN on account thereof, pay all judgments rendered against FTN therein, and reimburse FTN in cash for all reasonable expense incurred by FTN on account thereof, provided, that if FTN elects to retain independent counsel, CLIENT

shall reimburse FTN for all costs reasonably incurred by FTN to defend itself through attorneys of FTN's choice.

5. Electronic Deliverables Any use or reuse of original or altered computer files by CLIENT or others without written verification by FTN for purposes other than for the specific purpose intended will be at CLIENT's risk and full legal responsibility. Furthermore, CLIENT will, to the fullest extent permitted by law, indemnify and hold FTN harmless from any and all claims, suits, liability, demands, or costs arising out of or resulting therefrom. Any verification of such adaptation by CLIENT will entitle FTN to additional compensation at the then current rate.

The submitted data files are intended to work only as described. The files are compatible only with the software and operating platform described. FTN makes no warranty as to the compatibility of these files for versions of the software other than for those stated. FTN is not responsible for uses of the data outside of or beyond the scope of the Agreement.

Because data stored on electronic media can deteriorate undetected or can be modified without FTN's knowledge, CLIENT agrees that FTN will not be held liable for the completeness or correctness of the electronic media, with respect to its originally intended use as defined in the agreement, after an acceptance period of 30 days after delivery of the electronic files. FTN stands by the accuracy of sealed drawings that accompany submittals.

The electronic files are submitted to CLIENT for a 30-day Acceptance Period. During this period, CLIENT may review and examine these files; any errors, relative to the intended use of the files, detected during this time will be corrected by FTN as part of the basic agreement. Any changes requested after the Acceptance Period will be considered additional services to be performed on a time and materials basis, at the then current rates plus terms and conditions.

6. Termination This agreement may be terminated at any time, for any cause by either party upon thirty days written notice to the other party. In such event, CLIENT shall forthwith pay FTN in full for all work previously authorized and performed prior to effective date of termination. If no notice of termination is given, relationships and obligations created by this Agreement shall be terminated upon completion of all applicable requirements of this Agreement.
7. Assignment This Agreement shall not be assigned by FTN to any other party unless prior written approval is obtained from CLIENT. This Agreement shall be binding upon all parties hereto and their respective heirs, executors, administrators, successors, and assigns.
8. Limit of Liability It is understood that any and all professional liabilities incurred by FTN throughout the course of rendering professional services on this Project shall be limited to a maximum of the net fee received by FTN, not including reimbursable expenses and subconsultants, for all services rendered on the Project.
9. Confidentiality of Information No information concerning this Project shall be released by FTN.

10. **Precedence** These Standard Terms and Conditions shall take precedence over any inconsistent or contradictory provisions contained in any proposal, contract, purchase order, requisition notice to proceed, or like document regarding FTN's services.
11. **Severability** If any of these Standard Terms and Conditions shall be finally determined to be invalid or unenforceable in whole or part, the remaining provisions hereof shall remain in full force and effect, and be binding upon the parties hereto. The parties agree to reform this Agreement to replace any such invalid or unenforceable provision with a valid and enforceable provision that comes as close as possible to the intention of the stricken provision.
12. **Survival** These Standard Terms and Conditions shall survive the completion of the services under this Agreement and the termination of this Agreement for any cause.
13. **Controlling Law** This Agreement is to be governed by and construed in accordance with the laws of the State of Arkansas.

EXHIBIT C

Existing Client Rates 2007 Fee Schedule¹ - FTN Associates, Ltd.

<u>Labor Category</u>	<u>Hourly Rate</u>
Professional 7	\$ 145.00
Professional 6	135.00
Professional 5	115.00
Professional 4	104.00
Professional 3	93.00
Professional 2	82.00
Professional 1	72.00
Technician 4	74.00
Technician 3	63.00
Technician 2	56.00
Technician 1	40.00
Word Processing	47.00

Direct Expenses

All direct project expenses will be invoiced at cost plus 10 percent. Direct project expenses include such items as travel, meals, lodging, shipping, supplies, consultants, subcontractors, etc. Vehicle mileage will be charged at standard IRS rates.

A charge of 2 percent is applied to the total labor amount to cover communication charges and computer expenses associated with computer applications, data storage and backup.

Should back-up data be requested for reimbursable expenses, it will be provided for an administrative fee.

Payment Terms

Unless other arrangements are made in writing invoicing will be monthly for services completed. Payment is due in full within 30 days of invoice. A service charge of 1. percent per month will be charged on all balances over 30 days.

¹Effective January 1, 2007 - December 31, 2007

Memo:

To: Mayor Tab Townsell

CC: City Council Members

From: Felicia Rogers

Date: February 5th, 2008

Re: Bid Number 2008-17, 2008-18, 2008-19 / Physical Plant Trucks

On Thursday, January 31st, 2008 in the Downstairs Conference Room in City Hall sealed bids were opened for the purchase of three different trucks for the Physical Plant. Bids tab are attached.

Please advise if you have any questions or need additional information.

2008-17 City of Conway Bid Tabulations
 Physical Plant
 Full Size Pickup Truckw/ Hitch

Vendor	Contact Person	Cost of Bid	Delivery Date	Make of Vehicle	Miscellaneous Information
Landers Ford, Lincoln, Mercury Benton, AR	Michael Beard	\$13,476.00	90 Days ARO	Ford	4.6L
Landers Ford, Lincoln, Mercury Benton, AR	Rick Layton	\$14,356.00	90 Days ARO	Ford	4.60L
Trotter Ford Pine Bluff, AR	Allen Funderburk	\$14,939.00	10-12 weeks	Ford	5.4L
Smith Ford Conway, AR	Roger Langely	\$15,265.00	6 weeks from order date	Ford	4.60L
Landers Ford, Lincoln, Mercury Benton, AR	Rick Layton	\$15,620.00	1 Day ARO	Ford / 4.6L	Alternative Bid

2008-18 City of Conway Bid Tabulations
 Physical Plant
 Full Size (1/2 Ton) 4x4

Vendor	Contact Person	Pickup Truck Cost of Bid	Delivery Date	Make of Vehicle	Miscellaneous Information
Landers Ford, Lincoln, Mercury Benton, AR	Michael Beard	\$17,277.00	90 Days ARO	Ford	4.6L
Landers Ford, Lincoln, Mercury Benton, AR	Rick Layton	\$18,284.00	90 Days ARO	Ford	4.6L
Trotter Ford Pine Bluff, AR	Allen Funderburk	\$18,664.00	10-12 weeks	Ford	5.4L
Smith Ford Conway, AR	Roger Langely	\$18,998.00	6 weeks from order date	Ford	4.6L
Landers Ford, Lincoln, Mercury Benton, AR	Rick Layton	\$19,478.00	1 Day ARO	Ford/ 4.6L	Alternative Bid

2008-19 City of Conway Bid Tabulations
 Physical Plant
 3/4 Ton Heavy Duty Pickup Truck Extended Cab

Vendor	Contact Person	Cost of Bid	Delivery Date	Make of Vehicle	Miscellaneous Information
Landers Ford, Lincoln, Mercury Benton, AR	Michael Beard	\$18,129.00	90 Days ARO	Ford	4.6L
Landers Ford, Lincoln, Mercury Benton, AR	Rick Layton	\$19,177.00	90 Days ARO	Ford	4.6L
Trotter Ford Pine Bluff, AR	Allen Funderburk	\$18,770.00	10-12 weeks	Ford	5.4L
Smith Ford Conway, AR	Roger Langely	\$20,470.00	6 weeks from order date	Ford	4.6L
Landers Ford, Lincoln, Mercury Benton, AR	Rick Layton	\$22,340.00	1 Day ARO	Ford / 4.6L	Alternative Bid

Memo:

To: Mayor Tab Townsell
CC: City Council Members
Mark Elsinger
From: Felicia Rogers
Date: February 5th, 2008
Re: Bid Number 2008-13 - Demolition of Structures

On Monday, January 28th, 2008 in the Downstairs Conference Room in City Hall sealed bids were opened for removal of structures located at 917 Siebenmorgan and 1001 Siebenmorgan, the bid tabs are attached.

The recommendation is for D&E House Moving to pay the City in the amount of \$12,098.00 for both structures and for A&B Dirt Movers to clean up both locations in the amount of \$4,800.00.

Please advise if you have any questions or need additional information.

2008-14 City of Conway Bid Tabulations
Demolition of Structures

	Ho Jo Construction	Blaineco Structural Movers	Controlled Environmental Solutions	Lipsmeyer Demolition, Inc.	A&B Dirt Movers	D&E Housemoving
Phase I - Building Removal	Amount to be paid to bidder	Amount to be paid to bidder	Amount to be paid to bidder	Amount to be paid to bidder	Amount to be paid to bidder	Amount to be paid to City
Removal of 917 Siebenmorgan Road	\$9,265.50	\$3,000.00	\$4,123.00	13,250.00	\$800.00	\$5,872.46
Removal of 1001 Siebenmorgan Road	\$12,555.00	\$3,000.00	\$3,918.00	\$11,250.00	\$800.00	\$6,225.84
Total Amount of Bid Building Removal	\$21,820.50	\$6,000.00	\$8,041.00	\$24,500.00	\$1,600.00	\$12,098.30
Phase 2 - Site Clean Up						
917 Siebenmorgan Road	\$5,500.00	xxxxx	\$3,773.00	xxxxx	\$2,400.00	\$8,645.00
1001 Siebenmorgan Road	\$4,567.50	xxxxx	\$2,875.00	xxxxx	\$2,400.00	\$10,875.50
Total Amount Bid Site Clean Up	\$10,067.50	xxxxx	\$6,648.00	xxxxx	\$4,800.00	\$19,521.00



CITY OF CONWAY
SANITATION DEPARTMENT

*P.O. Box 915
4550 Hwy. 64 West
Conway, AR 72033
(501) 450-6155
Fax: (501) 450-6157*

6B-4

Cheryl Harrington
Director

January 31, 2008

Mayor Tab Townsell
City Hall
1201 Oak Street
Conway, AR 72032

Re: 2008 Commercial Rear Load Refuse Truck

Dear Mayor Townsell,

Bids were submitted at 10:00 am, Wednesday January 30, 2008 at Conway City Hall for 2008 Commercial Rear Load Refuse Truck. Four bids were submitted:

Truck Centers of Arkansas	\$127,948.00
Roy Conley & Company, Inc.	\$133,370.00
River City Hydraulics, Inc.	\$139,500.00
Wayne Engineering	\$149,688.00

I recommend the bid from Truck Centers of Arkansas for \$127,948.00. It was the bid that met or exceeded all specifications that we required.

Please advise if you have questions or need additional information.

Sincerely,

Cheryl Harrington
Sanitation Director

BID SUMMARY
2008 Commercial Rear Load Refuse Truck

Bid #1 submitted by Truck Centers of Arkansas
1-2009 Freightliner M2-106chassis & 25 yard Load Loadmaster
\$127,948.00
Bid price held until 12/31/2008
Delivery time 120 days

Bid #2 submitted by Roy Conley & Company, Inc.
1-2008 Loadmaster Excel 25 yd Rear Load with 2009 Freightliner M2
\$133,370.00
Delivery time 160-210 Days

Bid #3 submitted by River City Hydraulics, Inc
1-2008 Commercial Rear Load Refuse Truck
\$139,500.00
Delivery time 120-150 Days

Bid #4 submitted by Wayne Engineering
1- 2008 Commercial Rear Load Refuse Truck
\$149,688.00
Delivery time 120 Days

I recommend accepting the bid from Truck Center of Arkansas with a bid of \$127,948.00. This truck meets all specifications. Prices include tax and delivery costs.

City of Conway
2008 Commercial Rear Load Refuse Truck
Bid Number: 2008-16
Bid Opening Date: Wednesday, January 30, 2008

Total Cost for 2008 Commercial Rear Load Refuse Truck

\$ 149,688.00

Authorized Agent Bidding on this project:

Wayne Engineering
Company Name

Troy Schuller
Company Representative Name

Troy Schuller
Representative's Signature

701 Performance Drive Tschuller@wayneusa.co
Address Email Address

Cedar Falls IA 50613
City State Zip

319-290-2882 319-266-8207
Telephone Number Fax Number

1-25-2008
Date

Unsigned bids will be rejected:

City of Conway
2008 Commercial Rear Load Refuse Truck
Bid Number: 2008-16
Bid Opening Date: Wednesday, January 30, 2008

Total Cost for 2008 Commercial Rear Load Refuse Truck

\$ 139,500.⁰⁰

DELIVERY - 120 to 150 DAYS ARO

Authorized Agent Bidding on this project:

RIVER CITY HYDRAULICS INC
Company Name

ROGER WILLIAMS - SALES MANAGER
Company Representative Name

Roger Williams
Representative's Signature

PO-Box 6033 vchroger@sbcglobal.net
Address Email Address

SHERWOOD Ar 72120
City State Zip

501-835-5230 501-834-1233
Telephone Number Fax Number

-29-2008
Date

Unsigned bids will be rejected:

City of Conway
2008 Commercial Rear Load Refuse Truck
Bid Number: 2008-16
Bid Opening Date: Wednesday, January 30, 2008

Total Cost for 2008 Commercial Rear Load Refuse Truck

\$ 133,370.00

Authorized Agent Bidding on this project:

Roy Conley & Company, Inc.
Company Name

Roy Conley
Company Representative Name

Roy Conley
Representative's Signature

ibn.net

Address Email Address

Butler MD _____
City State Zip

(410) 679-1600 (410) 679-1660
Telephone Number Fax Number

1/28/08
Date

Unsigned bids will be rejected:

City of Conway
2008 Commercial Rear Load Refuse Truck
Bid Number: 2008-16
Bid Opening Date: Wednesday, January 30, 2008

Total Cost for 2008 Commercial Rear Load Refuse Truck

\$ 127,948.⁰⁰

Authorized Agent Bidding on this project:

Truck Centers of Arkansas
Company Name

Tommy Lawrence
Company Representative Name

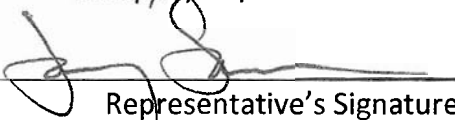
Representative's Signature

11700 Valentine Rd. tlawrence@conwaycorp.net
Address Email Address

North Little Rock AR 72117
City State Zip

501-955-3200 501-907-2066
Telephone Number Fax Number

1-28-08
Date

Unsigned bids will be rejected:

Cheryl Harrington
Director

CITY OF CONWAY
SANITATION DEPARTMENT

*P.O. Box 915
4550 Hwy. 64 West
Conway, AR 72033
(501) 450-6155
Fax: (501) 450-6157*



January 31, 2008

Mayor Tab Townsell
City Hall
1201 Oak Street
Conway, AR 72032

Re: 2008-11 Yard Commercial Rear Load Refuse Truck

Dear Mayor Townsell,

Bids were submitted at 10:00 am, Wednesday January 30, 2008 at Conway City Hall for 2008-11 Yard Commercial Rear Load Refuse Truck. Two bids were submitted:

Downing Sales & Service, Inc.	\$99,380.00
Wayne Engineering	\$102,816.00

I recommend the bid from Downing Sales & Service, Inc. for \$99,380.00. It was the bid that met or exceeded all specifications that we required.

Please advise if you have questions or need additional information.

Sincerely,

Cheryl Harrington
Sanitation Director

BID SUMMARY
2008-11yd Commercial Rear Load Refuse Truck

Bid #1 submitted by Downing Sales & Service, Inc.
1-2008 Commercial 11 Yard Rear Load Refuse Truck
\$99,380.00
Delivery time 4-6 weeks

Bid #2 submitted by Wayne Engineering
1-2008 Commercial 11 Yard Read Load Refuse Truck
\$102,816.00
Delivery time 60 Days

I recommend accepting the bid from Downing Sales & Service, Inc. with a bid of \$99,380.00. This truck meets all specifications. Prices include tax and delivery costs.

City of Conway
2008 Commercial 11 yard Rear Load Refuse Truck
Bid Number: 2008-15
Bid Opening Date: Wednesday, January 30, 2008

Total Cost for 2008 Commercial 11 Yard Rear Load Refuse Truck

\$ 99,380.00

Authorized Agent Bidding on this project:

Downing Sales & Service, Inc.

Company Name

Daniel Ellison

Company Representative Name



Representative's Signature

<u>5841 HWY 9</u>	<u>downing@downingsales.com</u>
Address	Email Address
<u>Malvern</u>	<u>AR</u>
City	State
<u>72104</u>	<u>Zip</u>
<u>888 589 6227</u>	<u>417 589 6753</u>
Telephone Number	Fax Number
<u>1/28/08</u>	
Date	

Unsigned bids will be rejected:

City of Conway
2008 Commercial 11 yard Rear Load Refuse Truck
Bid Number: 2008-15
Bid Opening Date: Wednesday, January 30, 2008

Total Cost for 2008 Commercial 11 Yard Rear Load Refuse Truck

\$ 102,816.00

Authorized Agent Bidding on this project:

Wayne Engineering
Company Name

Troy Schuller
Company Representative Name

Troy Schuller
Representative's Signature

701 performance Drive tschuller@wayneusa.co.
Address Email Address

Cedar Falls IA 50615
City State Zip

319-290-2882 319-266-8207
Telephone Number Fax Number

1-25-2008
Date

To go with 12 yd Body (same as 11 yd uses wider body)
Deduct \$ 2,350 from Above Price for a total Bid of

\$ 100,466.00

Unsigned bids will be rejected:

Sanitation CDL Position Reclassification - Fringe Benefit Costs

Employee Salary	Social Security	Medicare	Non-Uniformed Pension	Benefits Cost	Additional Benefit Cost	No. Employees in grade/step	Total Additional Benefit Cost
	6.20%	1.45%	6%				
Grade 8 Step 1							
12.55 X 1760							
22088	1369	320	1325	3015			
10.92 X 1760							
19219	1192	279	1153	2623	392	6	2350
Grade 8 Step 2							
13.12 X 1760							
23091	1432	335	1385	3152			
11.46 X 1760							
20170	1251	292	1210	2753	399	1	399
Grade 8 Step 3							
13.68 X 1760							
24077	1493	349	1445	3286			
12.01 X 1760							
21138	1311	306	1268	2885	401	1	401
Grade 8 Step 4							
14.24 X 1760							
25062	1554	363	1504	3421			
12.56 X 1760							
22106	1371	321	1326	3017	404	2	807
Grade 8 Step 5							
14.81 X 1760							
26066	1616	378	1564	3558			
13.10 X 1760							
23056	1429	334	1383	3147	411	2	822
Grade 60 Step 5							
14.81 X 1760							
26066	1616	378	1564	3558			
13.80 X 1760							
24288	1506	352	1457	3315	243	1	243
Grade 8 Step 7							
15.93 X 1760							
28037	1738	407	1682	3827			
14.19 X 1760							
24974	1548	362	1498	3409	418	4	1672
Grade 59 Step 7							
15.93 X 1760							
28037	1738	407	1682	3827			
14.72 X 1760							
25907	1606	376	1554	3536	291	1	291
Total Additional Benefit Cost							6984

	Service Proposal
X	Reclassification

City of Conway Service Proposal & Reclassification Request

Attach your back-up to this form when submitting Service Proposals and Reclassification Requests to the Budget Office.

Department / Division Name	Sanitation
-----------------------------------	------------

	Position Title	Pay Grade	Annual Salary
Proposed:	Construction Specialist/Sanitation CDL	12	26,112.32
Current:	CDL Driver	8	22,709.00
Current:	CDL Driver with Journeyman License	59	23,797.00
Current:	CDL Driver with Master License	60	24,159.00

"Current" information needed for reclassification only

Estimated Cost of Position:

Expenses:	
Salary Cost (when reclass, calculate the difference between current & proposed only)	48,279.00
Benefits (FICA-Medicare & Non-Uniform Pension Only)	6,984.00
Total	55,263.00

Salary and benefit costs are based on the costs for 11 months

Estimated Operating Expenses: Account Number / Name	Amount
Total Operating Expenses	-

Estimated Capital Expenses: Account Number / Name	Amount
Total Capital Expenses	-

Total Estimated Cost of New Position	
---	--



**City of Conway, Arkansas
Ordinance No. O-08-_____**

AN ORDINANCE WAIVING BIDS FOR THE PURCHASE OF A FIRE EXTINGUISHER TRAINING SYSTEM; DECLARING AN EMERGENCY AND FOR OTHER PURPOSES;

WHEREAS, the City of Conway Fire Department has a need for a fire extinguisher training system and has located a single source for the product; and

NOW THEREFORE BE IT ORDAINED BY THE CITY COUNCIL OF THE CITY OF CONWAY, ARKANSAS, THAT:

Section 1. The City of Conway shall waive the requirements for obtaining bids for the purchase of a fire extinguisher training system and shall utilize BullEx, Inc. as a single source vendor.

Section 2. This ordinance is necessary for the protection of the public peace, health and safety; an emergency is hereby declared for exist, and this ordinance shall be in full force and effect from and after its passage and approval.

Section 3. All ordinances in conflict herewith are repealed to the extent of the conflict.

PASSED this 12th, day of February, 2008.

Approved:

Mayor Tab Townsell

Attest:

Michael O. Garrett
City Clerk/Treasurer



City of Conway, Arkansas
Ordinance No. O-08-_____

AN ORDINANCE AMENDING ORDINANCE O-07-108 (THIRD PARTY REVIEW); DECLARING AN EMERGENCY; AND FOR OTHER PURPOSES.

WHEREAS, the City of Conway finds it beneficial to clarify procedures and permit requirements and providing for third party review of fire code requirements for building construction or alteration;

NOW THEREFORE, BE IT ORDAINED BY THE CITY COUNCIL OF THE CITY OF CONWAY, ARKANSAS, THAT:

Section 1. In Section 2 the following sections should be completely removed. They are as follows: 2(a), 2(b), 2(c) and 2(d)

When local permits are obtained for the construction or substantial remodeling of any;

- a) ~~Asylums, hospitals, nursing or convalescent homes, regardless of capacity.~~
- b) ~~Schools and educational institutional having a capacity in excess of fifty (50) pupils, and residence buildings, including dormitories, having sleeping accommodations for fifty (50) or more persons.~~
- c) ~~Auditoriums, theaters, indoor stadiums, gymnasiums.~~
- d) ~~Department stores or factories having a capacity in excess of two hundred (200) persons.~~

2 (e) should read: Buildings containing hazardous occupancies if located with the City.

- e) ~~Any other~~ building containing hazardous occupancies if located within the City.

Section 2. All other parts and enumerated paragraphs in Section 2 remain intact unamended, and are in full force and effect.

Section 3. That any ordinance in conflict herewith is hereby repealed to the extent of that conflict.

Section 4. That this ordinance is necessary for the protection of the peace, health and safety of the citizens of Conway, and therefore, an emergency is declared to exist, and this ordinance shall go into effect from and after its passage and approval.

PASSED this 12th day of February, 2008.

Approved:

Mayor Tab Townsell

Attest:

Michael O. Garrett
City Clerk/Treasurer



City of Conway, Arkansas
Ordinance No. O-08-_____

AN ORDINANCE ACCEPTING INSURANCE PROCEEDS TO REPAIR DAMAGED PATROL VEHICLE; AND FOR OTHER PURPOSES

WHEREAS, the City of Conway has received a check in the amount of \$3093.64 from the Municipal League insurance company to repair a damaged 2006 Ford Crown Victoria patrol vehicle;

NOW, THEREFORE, BE IT ORDAINED BY THE CITY COUNCIL OF THE CITY OF CONWAY, ARKANSAS THAT:

Section 1. The City of Conway shall accept the check in the amount of \$3093.64 and shall appropriate the funds into the police vehicle maintenance account, 01.113.234

Section 2. All ordinances in conflict herewith are repealed to that extent of the conflict.

PASSED this 12th day of February, 2008

APPROVED:

Mayor Tab Townsell

ATTEST:

Michael O. Garrett
City Clerk/Treasurer



**City of Conway, Arkansas
Ordinance No. O-08-_____**

**AN ORDINANCE APPROPRIATING FUNDS TO THE CONWAY POLICE DEPARTMENT FOR
BUILDING REPAIRS, AND FOR OTHER PURPOSES:**

WHEREAS, the Conway Police Department requests a revenue appropriation of \$ 10,000 to for building maintenance; and

WHEREAS, the Conway Police Department has a need for general building maintenance;

WHEREAS, funds for line item 01.113.231, Building Maintenance was not included in the 2008 Police Department Budget;

**NOW THEREFORE BE IT ORDAINED BY THE CITY COUNCIL OF THE CITY OF
CONWAY, ARKANSAS THAT:**

SECTION 1. The City of Conway shall appropriate \$10,000 from the General Fund Balance account (01.990) to the Building Repairs and Maintenance Account (01.113.231).

SECTION 2. All ordinances in conflict herewith are repealed to the extent of the conflict.

PASSED this 12th day of February 2008.

APPROVED:

Mayor Tab Townsell

ATTEST:

**Michael O. Garrett
City Clerk/Treasurer**

2008 Uniform Bid Tabulations/Breakdown
Bid Number: 2008-12

Sealed bids were opened on January 18, 2008 at 10 am at City Hall. Four bids were received. The breakdown is as follows for a new hire with the City Police Department.

- 1) Galls - \$916.74
- 2) Cruse Uniforms - \$1137.15
- 3) Conway Police Supply - \$1204.10
- 4) Direct Police Sales – \$1110.41 (Failure to meet bid specifications)

When figuring the above totals I figured what the cost to outfit a new hire would be. The reasoning behind that is the fact that in 2007, our department had to outfit 25 new hires. The cost to do so is significant. Thus the above totals include what we would purchase for a new hire of the items bid.

In 2006 our uniform bid was awarded to Galls. Galls definitely has the lowest price. They are a large mail/internet/catalog supplier. By March/April of 2006 we were already trying to figure if or how we could get out of the contract with them. What we experienced was a very difficult situation. Although their prices are very low, they charge very high shipping/handling charges on everything we order (by looking at previous invoices, we were charged anywhere from 10% to 18%). I was required to maintain a large stock of everything and we experienced a lot of items being backordered. The situation just simply did not work. A lot of times when we hire people, they are only in our building for a few days before they leave for the police academy. When they go to the academy they need 90% of their equipment. That just was not possible with Galls. We had no idea when we would receive the items ordered. Returns were also very difficult. We were responsible for return shipping which became very expensive.

In my bid specifications, I stated that “No Substitutions” would be accepted on the uniform items themselves. The bid we received from Direct Police Sales was on a completely different uniform than the one specified. We have been very happy with our current uniforms and do not wish to deviate from that. We are attempting to reach the point where all of our officers are in the same uniform. If the uniform is changed every year we will never reach that goal. So it is my recommendation that the bid from Direct Police Sales be thrown out/not considered for failing to meet bid specifications.

It is my opinion that this bid should come down to two (2) vendors, Cruse Uniforms (Little Rock) and Conway Police Supply (Conway). There was only a slight difference in price as you can see above. Conway Police Supply had the uniform bid this year (2007) and I have nothing but good things to say about them. The service we have received with them has been exceptional! On the bid submitted by Cruse Uniforms they stated

that a charge of \$7.95 would be added to all orders under \$150.00. If you factor in the fact that 42% of our invoices last year were under that dollar amount then in most cases that would raise their price/cost above Conway Police Supply. Also, they are located in Little Rock. I make numerous trips to the uniform vendor every week, and the cost of fuel to Little Rock would be significant along with my time away from the office. In addition, all new hires have to go to the vendor to be sized. It is very common for little emergencies to crop up that need to be addressed immediately. So far this year, I have had a couple of officers that needed a coat for that nights shift and I was able to send the coat down to Conway Police Supply and within minutes had all the patches/namestrips sewn onto the coat so the officer could use it immediately. That simply would not be possible if our supplier was in Little Rock.

The bottom line is without factoring in the shipping/handling charge that Cruse will impose there is only a difference in \$66.95 per new hire/complete outfitting between Conway Police Supply and Cruse. If you factor in that extra charge for Cruse, then in most cases Conway Police Supply would be cheaper. **It is my recommendation that the bid be awarded to Conway Police Supply. They are a local Conway vendor (Shop Conway First), it would save me the down time and fuel of driving back and forth to Little Rock several times a week, and if you factored in the handling charge that will be imposed by Cruse, then the cost difference between the two vendors is even less.**

Chelley Harvill
Purchasing Agent/Quartermaster
Conway Police Department