



# City of Conway Council Agenda

**Council Meeting Date:** Tuesday, July 22<sup>nd</sup>, 2014

**5:30pm – Committee Meeting:** No Committee Meeting

6:30pm - Council Meeting

Call to Order: Mayor Tab Townsell

Roll Call: City Clerk/Treasurer Michael O. Garrett

Minutes Approval: July 8<sup>th</sup>, 2014

Employee Service Awards

**Mayor Tab Townsell**

City Clerk Michael O. Garrett  
City Attorney Michael Murphy

City Council Members

Ward 1 Position 1 – Andy Hawkins

Ward 1 Position 2 – David Grimes

Ward 2 Position 1 – Wesley Pruitt

Ward 2 Position 2 – Shelley Mehl

Ward 3 Position 1 – Mark Ledbetter

Ward 3 Position 2 – Mary Smith

Ward 4 Position 1 – Theodore Jones Jr.

Ward 4 Position 2 – Shelia Whitmore

---

**1. Report of Standing Committees:**

**A. Community Development Committee (Planning, Zoning, Permits, Community Development, Historic District, Streets, & Conway Housing Authority)**

1. Resolutions requesting the Faulkner County Tax Collector place to place certified liens on certain properties as a result of incurred expenses by the City.
2. Consideration to approve the street tree planting and tree wells along Oak Street and Harkrider Street.
3. Resolution expressing the willingness of the City of Conway to partner with the AHTD for the project on Dave Ward Drive I-40 to East German Lane.
4. Resolution expressing the willingness of the City to partner with the AHTD for the project I-40/Hwy 64 traffic operations improvements.

**B. Public Services Committee (Sanitation, Parks & Recreation & Physical Plant)**

1. Consideration to approve the bid for a 20, 30, & 40 yard Hook Lift Roll-off containers for the Conway Sanitation Department.

**C. Finance**

1. Consideration to approve the monthly financial report ending June 30, 2014.

**Adjournment**



# MEMO

**TO:** Mayor Tab Townsell  
**CC:** City Council Members  
**FROM:** Missy Schrag  
**DATE:** July 15, 2014  
**SUBJECT:** Certified Liens – Code Enforcement

The following resolutions are included for a request to the Faulkner County Tax collector to place a certified lien against real property as a result of incurred expenses by the City.

The properties & amount (plus a ten percent collection penalty) are as follows:

- |                  |          |
|------------------|----------|
| 1. 2008 Millwood | \$197.56 |
| 2. 1628 Duncan   | \$198.65 |

Please advise if you have any questions.

Thank you for your consideration.



**City of Conway, Arkansas**  
**Resolution No. R-14-\_\_\_\_\_**

**A RESOLUTION REQUESTING THE FAULKNER COUNTY TAX COLLECTOR PLACE A CERTIFIED LIEN AGAINST REAL PROPERTY AS A RESULT OF INCURRED EXPENSES BY THE CITY OF CONWAY; AND FOR OTHER PURPOSES.**

**WHEREAS**, in accordance with Ark. Code Ann. § 14-54-901, the City of Conway has corrected conditions existing on **2008 Millwood** within the City of Conway and is entitled to compensation pursuant to Ark. Code § 14-54-904: and

**WHEREAS**, State law also provides for a lien against the subject property, with the amount of lien to be determined by the City Council at a hearing held after the notice to the owner thereof by certified mail with said amount **\$197.56** (\$152.33 + Penalty-\$15.23 + filing fee-\$30.00) to be thereafter certified to the Faulkner County Tax Collector; and

**WHEREAS**, a hearing for the purpose of determine such lien has been set for **July 22, 2014** in order to allow for service of the attached notice of same upon the listed property owners, by certified or publication as is necessary.

**NOW THEREFORE BE IT RESOLVED** that the City Council of the City of Conway, Arkansas that:

**SECTION 1:** That after said public hearing the amount listed above is hereby certified and is to be forwarded to the Faulkner County Tax Collector and Assessor by the City of Conway.

**SECTION 2:** That this Resolution shall be in full force and effect from and after its passage and approval.

**ADOPTED** this 22<sup>nd</sup> day of July, 2014.

**Approved:**

\_\_\_\_\_  
**Mayor Tab Townsell**

**Attest:**

\_\_\_\_\_  
**Michael O. Garrett**  
**City Clerk/Treasurer**

**City of Conway**  
Code Enforcement  
1201 Oak Street  
Conway, Arkansas 72032



**Missy Schrag**  
Administrative Assistant  
Phone: 501-450-6191  
Fax: 501-450-6144

## MEMO:

To: Mayor Tab Townsell  
CC: City Council Members

From: Missy Schrag  
Date: July 15, 2014

Re: 2008 Millwood

---

- April 25, 2014– Warning Violation written regarding grass, rubbish/trash, appliance/furniture in the yard by Kim Beard.
- Property Owner is listed as Kenneth Young.
- Property was rechecked on 5/5&13/14 with no progress made.
- Certified and regular letters were mailed 5/13/14 to address on file and a notice was left by post office and returned.
- Property was rechecked on 6/10/14 with no action taken.
- Final Cleanup finished on 6/16/14.
- Certified and regular letters were sent including date, time & place of the City Council meeting.

If you have any questions please advise.

# INVOICE

## City of Conway Code Enforcement

DATE: JULY 17, 2014

1201 Oak Street  
Conway, AR 72032  
Phone: 501-450-6191  
Fax 501-450-6144  
missy.schrag@cityofconway.org

TO Kenneth Young  
2008 Millwood  
Conway, AR 72032

Description: Mowing/Clean-up/Admin Fees  
associated with the nuisance abatement at  
130 Oaklawn, Conway Arkansas

CODE ENFORCEMENT OFFICER	PARCEL NUMBER	PAYMENT TERMS	DUE DATE
Kim Beard	710-02221-000		July 22, 2014

HOURS	DESCRIPTION	UNIT PRICE	LINE TOTAL	
1	1 Employee -Cleanup	17.90	17.90	
1	1 Employee -Cleanup	15.23	15.23	
2	2 Employee -Cleanup	10.48	20.96	
	Landfill Fees (#481941)	32.63	32.63	
1	Administrative Fee (Missy Schrag)	18.03	18.03	
1	Administrative fee (Kim Beard)	15.36	15.36	
1	Administrative Fee (Glenn Berry)	21.00	21.00	
2	Certified Letter	5.13	10.26	
2	Regular letter	.48	.96	
TOTAL BY 7/22/14			\$152.33	
<ul style="list-style-type: none"><li>Total amount due after July 8, 2014 includes collection penalty &amp; filing fees</li></ul>			TOTAL AFTER 7/22/14	\$197.56

Make all checks payable to City of Conway Code Enforcement @ 1201 Oak Street Conway Arkansas 72032

**City of Conway**  
**Code Enforcement**

1201 Oak Street  
Conway, Arkansas 72032  
[www.cityofconway.org](http://www.cityofconway.org)



*Missy Schrag*

Conway Permits & Code Enforcement  
Phone 501-450-6107  
Fax 501-450-6144

June 23, 2014

**Parcel # 710-02221-000**

Kenneth Young  
2008 Millwood  
Conway, Ar 72032

**RE: Nuisance Abatement at 2008 Millwood, Conway AR**  
**Cost of Clean-Up, Amount Due: \$152.33**

Dear Mr. Young,

Because you failed or refused to remove, abate or eliminate certain conditions on the aforementioned real property in the City of Conway, after having been given seven (7) days notice in writing to do so, the City of Conway was forced to undertake the cleanup of this property to bring it within compliance of the Conway Municipal Code.

The City of Conway is requesting payment for all costs expended in correcting said condition. If after thirty (30) days from the receipt of this letter notifying you of the cost to correct said condition, such payment has not been remitted to the City, the City has the authority to file a lien against real estate property for the cost expended after City Council approval.

At its **July 22, 2014 Meeting**, 6:30 p.m. located at 810 Parkway Street, the City Council will conduct a public hearing on three items:

1. Consideration of the cost of the clean-up of your real property.
2. Consideration of placing a lien on your real property for this amount.
3. Consideration of certifying this amount determined at the hearing, plus a ten percent (10%) penalty for collection & filing fees, to the Tax Collector of Faulkner County to be placed on the tax books as delinquent taxes and collected accordingly.

None of these actions will be necessary if full payment is received before the meeting date. Please make check payable to the **City of Conway** and mail to **1201 Oak Street Conway Arkansas 72032** with the **attention** to **Missy Schrag**. If you have any questions, please feel free to call me at 501-450-6191.

Sincerely,

Missy Schrag

**Conway Code Enforcement  
Incident Report**

**Date of Violation: 04/25/2014**

**Violator Name: Kenneth Young**

**Address of Violation: 2008 Millwood**

**Violation Type: Grass/Rubbish/Trash/Furniture in yard**

**Warning #: CE8392**

**Description of Violation and Actions Taken: On 04/25/14, Code Enforcement Officer Kim Beard wrote a warning to correct violation at 2008 Millwood for overgrown grass, rubbish/trash and a table in the yard. On 05/05/14 a recheck was conducted and there was no progress made. A second recheck was conducted on 05/13/14 with no progress. Certified letter was sent on 05/13/14. A final recheck was conducted on 06/10/14 and there was no progress. Cleanup was scheduled. Cleanup was completed on 06/16/14.**

**Code Enforcement Officer: Kim Beard**

**Officer Signature: \_\_\_\_\_**

**Date:**

**Time:**



**City of Conway, Arkansas**  
**Resolution No. R-14-\_\_\_**

**A RESOLUTION REQUESTING THE FAULKNER COUNTY TAX COLLECTOR PLACE A CERTIFIED LIEN AGAINST REAL PROPERTY AS A RESULT OF INCURRED EXPENSES BY THE CITY OF CONWAY; AND FOR OTHER PURPOSES.**

**WHEREAS**, in accordance with Ark. Code Ann. § 14-54-901, the City of Conway has corrected conditions existing on **1628 Duncan** within the City of Conway and is entitled to compensation pursuant to Ark. Code § 14-54-904: and

**WHEREAS**, State law also provides for a lien against the subject property, with the amount of lien to be determined by the City Council at a hearing held after the notice to the owner thereof by certified mail with said amount **\$198.65** (\$153.32 + Penalty-\$15.33 + filing fee-\$30.00) to be thereafter certified to the Faulkner County Tax Collector; and

**WHEREAS**, a hearing for the purpose of determine such lien has been set for **July 22, 2014** in order to allow for service of the attached notice of same upon the listed property owners, by certified or publication as is necessary.

**NOW THEREFORE BE IT RESOLVED** that the City Council of the City of Conway, Arkansas that:

**SECTION 1:** That after said public hearing the amount listed above is hereby certified and is to be forwarded to the Faulkner County Tax Collector and Assessor by the City of Conway.

**SECTION 2:** That this Resolution shall be in full force and effect from and after its passage and approval.

**ADOPTED** this 22<sup>nd</sup> day of July, 2014.

**Approved:**

\_\_\_\_\_  
**Mayor Tab Townsell**

**Attest:**

\_\_\_\_\_  
**Michael O. Garrett**  
**City Clerk/Treasurer**



**City of Conway**  
Code Enforcement  
1201 Oak Street  
Conway, Arkansas 72032



**Missy Schrag**  
Administrative Assistant  
Phone: 501-450-6191  
Fax: 501-450-6144

## MEMO:

To: Mayor Tab Townsell  
CC: City Council Members

From: Missy Schrag  
Date: July 15, 2014

Re: 1628 Duncan

---

- April 18, 2014– Warning Violation written regarding grass, rubbish & trash in the yard by Kim Beard.
- Property Owner is listed as J Leann Weaver.
- Property was rechecked on 4/28/14 & 5/6&13/14 with no progress made.
- Certified and regular letters were mailed 5/21/14 to address on file and a notice was left by post office then returned.
- Property was rechecked on 6/6/14 with no action taken.
- Final Cleanup finished on 6/10/14.
- Certified and regular letters were sent including date, time & place of the City Council meeting.

If you have any questions please advise.

**City of Conway**  
**Code Enforcement**

1201 Oak Street  
Conway, Arkansas 72032  
[www.cityofconway.org](http://www.cityofconway.org)



*Missy Schrag*

Conway Permits & Code Enforcement  
Phone 501-450-6107  
Fax 501-450-6144

June 12, 2014

**Parcel # 710-02652-000**

Samantha Warner  
J Leann Weaver  
1628 Duncan St  
Conway, AR 72034

**RE: Nuisance Abatement at 1628 Duncan St, Conway AR**  
**Cost of Clean-Up, Amount Due: \$153.32**

Dear Samantha and/or Leann,

Because you failed or refused to remove, abate or eliminate certain conditions on the aforementioned real property in the City of Conway, after having been given seven (7) days notice in writing to do so, the City of Conway was forced to undertake the cleanup of this property to bring it within compliance of the Conway Municipal Code.

The City of Conway is requesting payment for all costs expended in correcting said condition. If after thirty (30) days from the receipt of this letter notifying you of the cost to correct said condition, such payment has not been remitted to the City, the City has the authority to file a lien against real estate property for the cost expended after City Council approval.

At its **July 22, 2014 Meeting**, 6:30 p.m. located at 810 Parkway Street, the City Council will conduct a public hearing on three items:

1. Consideration of the cost of the clean-up of your real property.
2. Consideration of placing a lien on your real property for this amount.
3. Consideration of certifying this amount determined at the hearing, plus a ten percent (10%) penalty for collection & filing fees, to the Tax Collector of Faulkner County to be placed on the tax books as delinquent taxes and collected accordingly.

None of these actions will be necessary if full payment is received before the meeting date. Please make check payable to the **City of Conway** and mail to **1201 Oak Street Conway Arkansas 72032** with the **attention** to **Missy Schrag**. If you have any questions, please feel free to call me at 501-450-6191.

Sincerely,

Missy Schrag

**Conway Code Enforcement  
Incident Report**

**Date of Violation: 04/18/2014**

**Violator Name: J Leann Weaver**

**Address of Violation: 1628 Duncan**

**Violation Type: Grass/Indoor couch in yard**

**Warning #: CE8384**

**Description of Violation and Actions Taken: On 04/18/14, Code Enforcement Officer Kim Beard wrote a warning to correct violation at 1628 Duncan for overgrown grass and a couch in the yard. On 04/28/14 a recheck was conducted and there was no progress made. A second recheck was conducted on 05/06/14 with no progress. A third recheck was conducted on 05/13/14 and there was no progress. Certified letter was sent on 05/21/14. A fourth recheck was conducted on 06/06/14 and there was no progress. Cleanup was scheduled. Cleanup was completed on 06/10/14.**

**Code Enforcement Officer: Kim Beard**

**Officer Signature: \_\_\_\_\_**

**Date:**

**Time:**



## Tree Board

City of Conway

1201 Oak Street Conway, AR 72032

501.450.6105 501.450.6144 (f)

July 16, 2014

Mayor and Conway City Council  
1201 Oak Street  
Conway, AR 72032

RE: Street Tree Planting and Tree Wells along Oak Street and Harkrider

Ladies and Gentlemen,

The attached information is a compilation of efforts from various sources to establish a standard street tree planting scheme for portions of Oak Street and Harkrider Street. The area in question is Oak Street from the new downtown archway on the west to Ingram Street on the east. Along Harkrider the corridor in question is from Hendrix College on the north to St. Joseph Church along the south. The concept behind this plan is for new developments and remodels within these stretches of road to continue the downtown feel and atmosphere beyond the traditional downtown areas, in essence to expand downtown. So, the proposed planting scheme will be implemented where new construction and remodels will allow for Street Tree planting in the public Right-of-Way.

The plans and sections you have before you are cooperative effort of the Conway Tree Board, the Conway Planning Department, and the Conway City Engineering Office. These concepts are what we as a collective group feel like will be the most appropriate and create the least amount of potential damage to infrastructure within these corridors.

It is our hope that you will adopt these plans and sections as standards for the corridors mentioned above from this day forward. We would hope that any project within this area, be it a remodel or new construction, will be held to this new standard along these portions of our public right-of-way.

Thank you for your consideration,

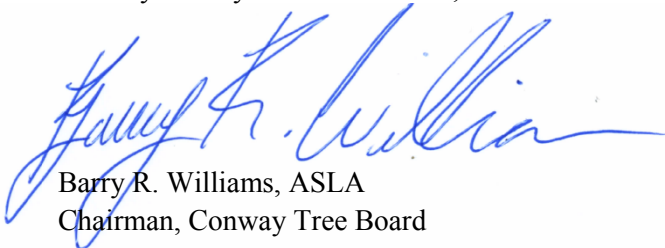

Barry R. Williams, ASLA  
Chairman, Conway Tree Board

# OAK STREET AND HARKRIDER STREET DOWNTOWN PLANTING WELL CROSS SECTION

## SPECIES ALLOWED

### Medium Trees:

- Nyssa sylvatica* - Black Gum
- Pistacia chinensis* - Chinese Pistache
- Gleditsia triacanthos* f. *inermis* 'Skycole' - Skyline Honeylocust
- Gleditsia triacanthos* f. *inermis* - Thornless Honeylocust

### Small Trees:

- Amelanchier arborea* - Serviceberry
- Acer buergeranum* - Trident Maple
- Chionanthus virginicus* - Fringe Tree
- Prunus x yedoensis* - Yoshino Cherry

### NOTE:

All the planting beds islands shall be fully planted with lower growing ground cover, shrubs, native or ornamental grass to fit the scale and context of a pedestrian corridor. No plant materials should exceed 3' tall at maturity, and the variety shall be at the discretion of the adjacent land owner to allow these beds to blend other plantings on the site.

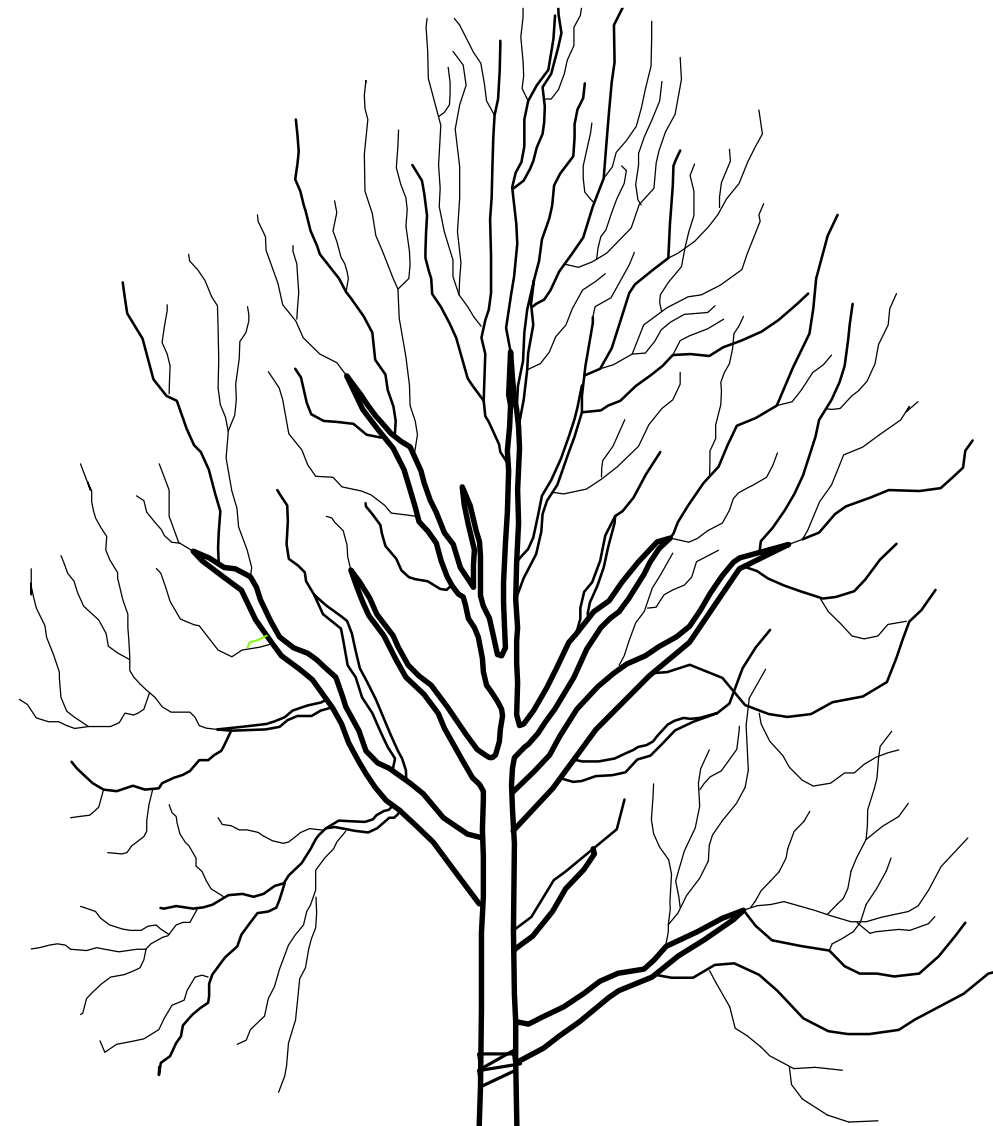
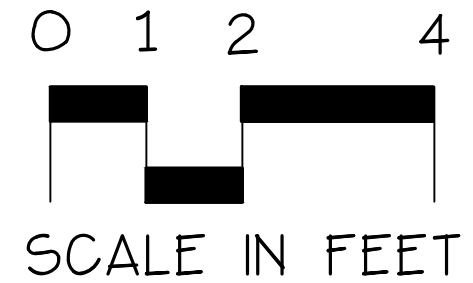

Typical Street

Typical Building

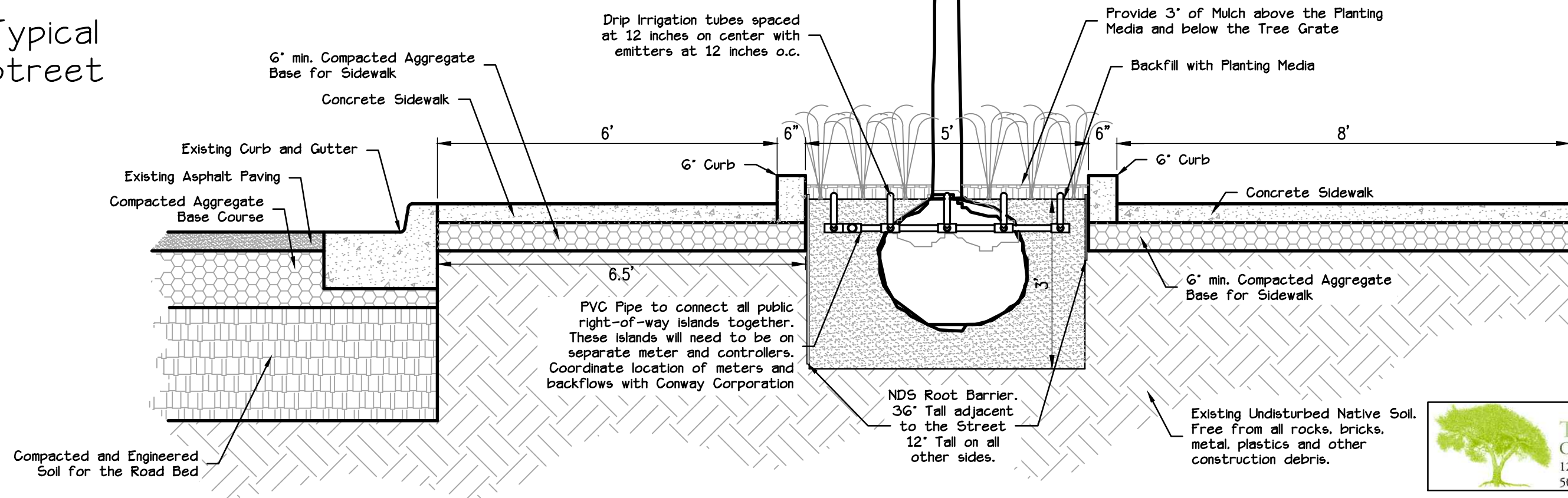

**Tree Board**  
City of Conway  
1201 Oak Street Conway, AR 72032  
501.450.6105 501.450.6144 (f)

# OAK STREET AND HARKRIDER STREET DOWNTOWN PLANTING WELL PLAN VIEW

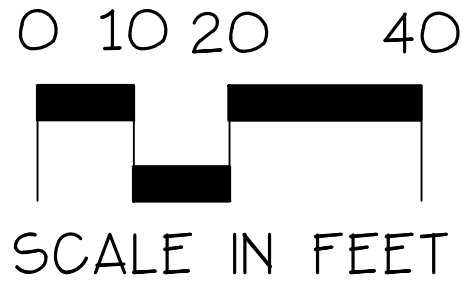

Typical Street

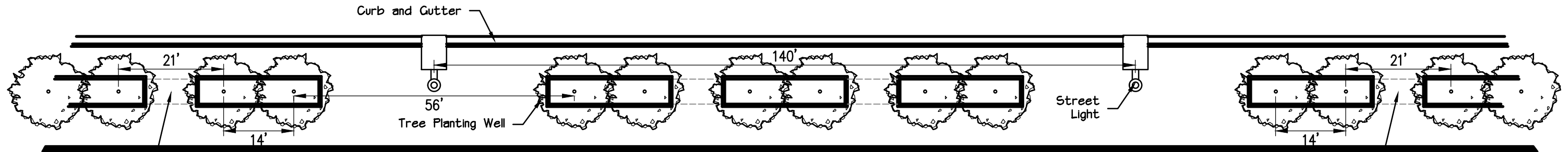

Provide growing media under the sidewalk and sidewalk base in the channels shown throughout to allow for additional root space!

Provide growing media under the sidewalk and sidewalk base in the channels shown throughout to allow for additional root space!

Typical Building Location

PLAN VIEW 'A'

Typical Street

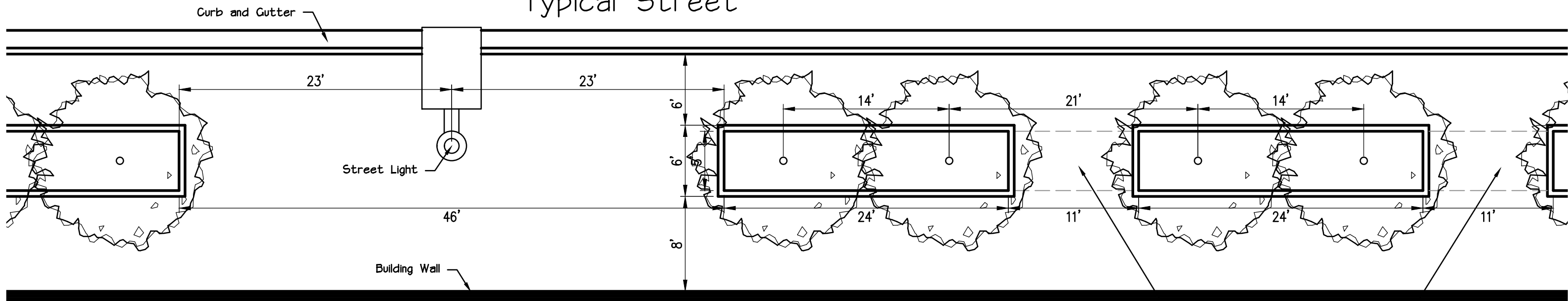

Provide growing media under the sidewalk and sidewalk base in the channel shown to allow for additional root space!

Typical Building Location

PLAN VIEW 'B'

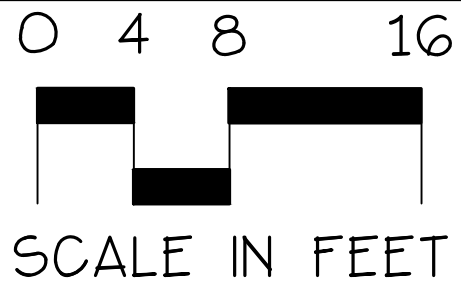



**City of Conway, Arkansas  
Resolution No. R-14-\_\_**

**A RESOLUTION EXPRESSING THE WILLINGNESS OF THE CITY OF CONWAY TO PARTNER WITH THE ARKANSAS STATE HIGHWAY AND TRANSPORTATION DEPARTMENT FOR THE FOLLOWING PROJECT:**

**DAVE WARD DRIVE - I-40 TO EAST GERMAN LANE**

**Whereas**, the City of Conway (the City) and the Arkansas State Highway and Transportation Department (the Department) have identified a need for improvements to the Interchange of Interstate 40 and Highway 65B and to Highway 286 from Interstate 40 to East German Lane and a study has shown that this is a viable project; and

**Whereas**, the Department is willing to handle all phases of the project; and

**Whereas**, the City will be responsible for relocating city owned utilities, and for providing \$2.0 million of project costs for matching funds for this project and the Oak Street project as described in Minute Orders 2014-080 and 2014-081 contingent upon the successful rededication of the city’s sales tax and outstanding bond issue on September 9, 2014; and

**Whereas**, on Amity Road, the existing roadway will be removed from the State Highway System and the City will be responsible for maintenance of this roadway; and

**Whereas**, it is recognized that significant changes in project construction cost or project design may necessitate adjustments to the project termini or to the funds committed to complete the projects as originally proposed, and indeed the city’s primary interest on Dave Ward Drive improvements at this time is from I-40 to Thomas G. Wilson Drive; and

**NOW, THEREFORE, BE IT RESOLVED BY THE CITY COUNCIL OF THE CITY OF CONWAY, ARKANSAS, THAT:**

**SECTION I:** The City will participate in accordance with its designated responsibilities in this project contingent upon the city’s successful sales tax rededication and bond issue and also agreeing to cover the Department’s engineering and design expenses on the Dave Ward Drive project incurred prior to the September 9, 2014 vote in the advent of an unsuccessful rededication.

**SECTION II:** The Mayor or his designated representative is hereby authorized and directed to execute all appropriate agreements and contracts necessary to expedite the construction of this project.

**SECTION III:** The City pledges its full support and hereby requests that the Department initiate action to implement this project.

**THIS RESOLUTION** adopted this 22<sup>nd</sup> day of July, 2014.

**Approved:**

**Attest:**

\_\_\_\_\_  
**Mayor Tab Townsell**

\_\_\_\_\_  
**Michael O. Garrett  
City Clerk/Treasurer**



**City of Conway, Arkansas  
Resolution No. R-14-\_\_\_\_\_**

**A RESOLUTION EXPRESSING THE WILLINGNESS OF THE CITY OF CONWAY TO PARTNER WITH THE ARKANSAS STATE HIGHWAY AND TRANSPORTATION DEPARTMENT FOR THE FOLLOWING PROJECT:**

**I-40/ HWY 64 TRAFFIC OPERATIONS IMPROVEMENTS.**

**Whereas**, a traffic analysis has been completed that evaluated various options to improve access to the future redevelopment of the former Cantrell Field Airport; and

**Whereas**, this analysis identified a need to improve traffic operations at the interchange of Interstate 40 and Highway 64; and

**Whereas**, the Arkansas State Highway and Transportation Department (the Department) is willing to handle all phases of the project; and

**Whereas**, the City of Conway (the City) will be responsible for relocating city owned utilities, and for providing \$2.0 million of project costs for matching funds for this project and the Dave Ward Drive project as described in Minute Orders 2014-080 and 2014-081 contingent upon the successful rededication of the city’s sales tax and outstanding bond issue on September 9, 2014; and

**Whereas**, it is recognized that significant changes to the estimated construction cost or project design may necessitate adjustments to the project termini or to the funds committed to complete the projects as originally proposed.

**NOW, THEREFORE, BE IT RESOLVED BY THE CITY COUNCIL OF THE CITY OF CONWAY, ARKANSAS, THAT:**

**SECTION I:** The City will participate in accordance with its designated responsibilities in this project contingent upon the city’s successful sales tax rededication and bond issue and also agreeing to cover the Department’s engineering and design expenses on the Dave Ward Drive project incurred prior to the September 9, 2014 vote in the advent of an unsuccessful rededication.

**SECTION II:** The Mayor or his designated representative is hereby authorized and directed to execute all appropriate agreements and contracts necessary to expedite the construction of this project.

**SECTION III:** The City pledges its full support and hereby requests that the Arkansas State Highway and Transportation Department initiate action to implement this project.

**THIS RESOLUTION** adopted this 22<sup>nd</sup> day of July, 2014.

**Approved:**

\_\_\_\_\_  
**Mayor Tab Townsell**

**Attest:**

\_\_\_\_\_  
**Michael O. Garrett  
City Clerk/Treasurer**





**CITY OF CONWAY**  
**SANITATION DEPARTMENT**  
*P.O. Box 915*  
*4550 Hwy. 64 West*  
*Conway, AR 72033*  
*(501) 450-6155*  
*Fax: (501) 450-6157*

**Cheryl Harrington**  
*Director*

June 8, 2014

Mayor Tab Townsell  
 1201 Oak Street  
 Conway, AR 72032

Re: 20, 30 & 40 yard Hook Lift Roll-off Containers

Dear Mayor Townsell,

Bids were submitted at 10.00 am, Wednesday, July 2, 2014 at City of Conway City Hall for 20, 30 & 40 yard Hook Lift Roll-off Containers. Three bids were submitted:

N.E.O. FAB

(2) 20 yard	\$7,300.00 total
(2) 20 yard with dump door & seal	\$8,500.00 total
(5) 30 yard	\$19,500.00 total
(1) 40 yard	\$4,350.00 total
Total pricing & delivery	\$41,900.00 total

Fudge's Freight Brokerage, Inc.

(2) 20 yard	\$8,550.00 total
(2) 20 yard with dump door & seal	\$9,900.00 total
(5) 30 yard	\$22,785.00 total
(1) 40 yard	\$5,063.00 total
Total pricing & delivery	\$46,298.00 total

Custom Container Solutions

(2) 20 yard	\$10,180.00 total
(2) 20 yard with dump door & seal	\$10,980.00 total
(5) 30 yard	\$26,950.00 total
(1) 40 yard	\$5,790.00 total
Total pricing & delivery	\$53,900.00 total

I recommend accepting Bid from N.E.O. FAB for a Total of \$41,900.00. This is the lowest bid and meets all bid specifications.

Please advise if you have questions or need additional information.

Sincerely,

*Cheryl Harrington*

Cheryl Harrington  
 Sanitation Director

**BID SUMMARY**  
**Bid #2014-14**  
**20, 30 & 40 Yard Roll-Off Containers**

Bid #1 submitted by N.E.O. FAB  
\$7,300.00 each (2) 20 yard  
\$8,500.00 each (2) 20 yard with dump door & seal  
\$19,500.00 each (5) 30 yard  
\$4,350.00 each (1) 40 yard  
Bid Total & Delivery \$41,900.00

Bid #2 submitted by Fudge's Freight Brokerage, Inc.  
\$8,550.00 each (2) 20 yard  
\$9,900.00 each (2) 20 yard with dump door & seal  
\$22,785.00 each (5) 30 yard  
\$5,063.00 each (1) 40 yard  
Bid Total & Delivered \$46,298.00

Bid #3 submitted by Custom Container Solutions  
\$10,180.00 each (2) 20 yard  
\$10,980.00 each (2) 20 yard with dump door & seal  
\$26,950.00 each (5) 30 yard  
\$5,790.00 each (1) 40 yard  
Bid Total & Delivery \$53,900.00

I recommend the bid from N.E.O. FAB for a total of \$41,900.00. The Containers suggested is the most reasonably priced and meets all bid specifications. Prices include tax and delivery costs.



City of Conway – Mayor’s Office  
Bid Number: 2014-14  
Conway Sanitation Department \_ Hook lift Roll Containers  
Bid Opening Date: Wednesday, July 2<sup>nd</sup>, 2014  
City Hall, Downstairs Conference Room @ 10:00am

**Authorized Agent bidding on this project:**

N.E.O. FAB  
Company Name

John Altemann  
Company Representative Name

[Signature] 6/25/14  
Representative’s Signature Date

604 Henley neofab@sbcglobal.net  
Address Email Address

Miami OK 74354  
City State Zip

918 ~~541~~-9203 918 541-9204  
Telephone Number Fax Number

**Unsigned bids will be rejected**

# **N. E. O. FAB**

604 Henley Boulevard

Miami, OK 74354

**Phone: 918 541-9203 Fax: 918 541-9204**

## **Prices for Bid No. 2014-14**

**All specifications are met.**

**2 - 20 yd = \$3650 each**

**2 - 20 yd with dump door and seal = \$4250 each**

**5 - 30 yd = \$3900 each**

**1 - 40 yd = \$4350 each**

**Freight = \$750 per load, 3 loads required to deliver**



City of Conway – Mayor's Office  
Bid Number: 2014-14  
Conway Sanitation Department \_ Hook lift Roll Containers  
Bid Opening Date: Wednesday, July 2<sup>nd</sup>, 2014  
City Hall, Downstairs Conference Room @ 10:00am

*Authorized Agent bidding on this project:*

Fudges Freight Brokerage, Inc.  
Company Name

Nancy Hargrove  
Company Representative Name

[Signature]  
Representative's Signature

Date

725 Locust Dr.  
Address

Email Address

Oak Leaf  
City

Texas  
State

75154  
Zip

972-228-5697  
Telephone Number

469-248-0116  
Fax Number

Unsigned bids will be rejected



P.O. BOX 2639 RED OAK, TEXAS 75154 PHONE 972 228-5697 FAX 469 218-0116

REF: SOLICITATION NUMBER 2014-14

WE ARE PLEASED TO PROVIDE A BID ON THE ABOVE REFERENCED SOLICITATION FOR SANITATIN HOOKLIFT ROLL-OFF CONTAINERS

2 - 20 yd STD = AS SPECIFIED \$4,275.00 EA X 2 = \$8,550.00

2 - 20 yd STD with dump door and seal = AS SPECIFIED \$4950 EA X 2 = \$9,900.00

5 - 30 yd STD = AS SPECIFIED \$4557 EA X 5 = \$22,785.00

1 - 40 yd STD = AS SPECIFIED \$5063 EA

BID TOTAL DELIVERED PRICING \$46,298.00

We are SAM, ORCA AND CCR REGISTERED, WE ACCEPT THE GOV'T IMPACT VISA CARD IF 3% IS ADDED TO TOTAL. WE ARE BIDDING FOB DESTINATION. OUR CAGE CODE IS 6PA95 AND OUR DUNS NUMBER IS 809509193. WE ARE A SMALL VETERAN OWNED COMPANY. OUR TAX ID NUMBER IS 75-2393630 AND OUR E-MAIL ADDRESS IS [Nancyh@fudgesfreight.com](mailto:Nancyh@fudgesfreight.com).

Thank you for the opportunity.

*Nancy Hargrove*

Fudges Freight Brokerage, Inc.

P. O. Box 2639

Red Oak, Texas 75154

972-228-5697 x 12

469-218-0114



City of Conway – Mayor’s Office  
Bid Number: 2014-14  
Conway Sanitation Department \_ Hook lift Roll Containers  
Bid Opening Date: Wednesday, July 2<sup>nd</sup>, 2014  
City Hall, Downstairs Conference Room @ 10:00am

**Authorized Agent bidding on this project:**

CUSTOM CONTAINER SOLUTIONS

Company Name

NORMAN RAY NATIONAL SALES MANAGER

Company Representative Name

6-25-14

Representative’s Signature

Date

391 WOLFLAND ROAD

nray01@snet.net

Address

Email Address

LEWISBURG,

PA.

17837

City

State

Zip

570-524-7835

570-524-5349

Telephone Number

Fax Number

NORMAN RAY CELL # 1-203-305-0901

**Unsigned bids will be rejected**

JUNE 24,2014  
NORMAN RAY  
NATIONAL SALES MANAGER  
203-305-0901  
[nray01@snet.net](mailto:nray01@snet.net)



CITY OF CONWAY,AR. BID #2014-14

WE ARE PLEASED TO OFFER THE FOLLOWING FOR YOUR  
REQUESTED PRICING FOR HOOK LIFT R.O.CONTAINERS

2-20 CU. YD. H.L.R.O. @ \$5090.00 EA. DELIVERED.

2-20 CU. YD. H.L.R.O. WITH DUMP, SEALED TAILGATE @  
\$5490.00 EA. DELIVERED.

5-30 CU. YD. H.L.R.O. @ \$5390.00 EA. DELIVERED.

1-40 CU. YD. H.L.R.O. @ \$5790.00 DELIVERED.

TOTAL DELIVERED PRICE FOR ALL 10 CONTAINERS IS  
\$53,900.00 THESE PRICES ARE VALID "ONLY" IF ALL 10  
CONTAINERS ARE AWARDED TO CCS. CUSTOMER IS  
RESPONSIBLE FOR UNLOADING OUR DELIVERY TRAILERS.



391 Wolfland Road / Lewisburg, PA / 17837 /  
570-524-7835 //  
[customcontainersolutions.com](http://customcontainersolutions.com)





City of Conway, Arkansas  
Monthly Financial Reports  
June 30, 2014

City of Conway  
 Monthly Financial Report - General Fund  
 For the month ended June 30, 2014



Revenues	Budget	Month	Year to	Encumbered	(Over)/Under	%
		Activity	Date		Budget	Expend/Collect
Ad Valorem Tax	2,960,000	604,916	846,452		2,113,548	29%
Payments in Lieu of Tax	25,000	104,794	104,794		(79,794)	419%
State Tax Turnback	1,995,402	59,217	411,206		1,584,196	21%
Sales Tax	17,350,000	1,330,220	7,904,327		9,445,673	46%
Beverage Tax	420,000	75	135,893		284,107	32%
Franchise Fees	2,655,000	191,458	1,229,164		1,425,836	46%
Airport Revenue	75,000	6,140	39,037		35,963	52%
Airport Fuel Sales .05 / GAL	10,000	825	3,847		6,153	38%
Permits	514,000	24,474	189,271		324,729	37%
ACIEA Revenues	-	1,006	2,585		(2,585)	-
Dog Tags & Fees	25,000	2,735	13,355		11,645	53%
Municipal Court Fines and Fees	990,000	103,010	625,303		364,697	57%
Law Enforcement	774,811	84,433	501,190		273,620	65%
Federal Grant Revenues	40,000	-	20,294		19,706	51%
Parks	493,500	37,992	314,052		179,448	64%
Interest Income	5,200	1,302	8,147		(2,947)	157%
Insurance Proceeds	36,311	1,733	37,565		(1,254)	103%
Donations	12,442	2,673	16,783		(4,341)	135%
Act 833 Revenue	80,000	-	44,316		35,684	55%
Miscellaneous Revenues	170,300	8,412	85,845		84,455	50%
Transfers from Other Funds	423,000	-	176,250		246,750	42%
Loan Proceeds	1,500,000	-	1,500,000		-	100%
Fund Balance Appropriation	75,000	-	-		75,000	0%
<b>Total Revenues</b>	<b>30,631,466</b>	<b>2,565,705</b>	<b>14,210,963</b>	<b>-</b>	<b>16,420,503</b>	<b>46%</b>
<b>Expenditures</b>						
Admin (Mayor, HR)	538,628	39,546	213,093	879	324,657	40%
Finance	495,937	27,548	206,332	70	289,535	42%
City Clerk/Treasurer	181,599	10,744	81,611	17	99,971	45%
City Council	81,915	6,997	37,107	-	44,808	45%
Planning	361,696	27,062	171,267	-	190,429	47%
Physical Plant	517,870	38,004	219,068	2,272	296,530	42%
Fleet Maintenance	145,358	14,310	66,784	8,193	70,382	46%
Information Technology	853,926	106,240	407,052	62,441	384,433	48%
Airport	1,532,500	271,799	1,079,496	66,848	386,157	70%
Permits and Inspections	530,383	40,927	252,118	-	278,265	48%
Nondepartmental	624,789	35,361	445,123	2,343	177,323	71%
Police	10,949,058	849,709	5,124,008	45,942	5,779,109	47%
Animal Welfare	432,921	30,770	178,374	17,317	237,230	41%
Municipal District Court	856,518	58,427	399,652	379	456,486	47%
City Attorney	356,462	26,960	161,808	187	194,468	45%
Fire	9,163,428	708,737	4,229,696	28,584	4,905,148	46%
Parks	2,822,640	207,737	1,165,069	22,920	1,634,651	41%
	30,445,628	2,500,878	14,437,657	258,390	15,749,581	47%
Transfer to Reserve	500,000	-	-	-	500,000	0%
<b>Total Expenditures</b>	<b>30,945,628</b>	<b>2,500,878</b>	<b>14,437,657</b>	<b>258,390</b>	<b>16,249,581</b>	<b>47%</b>
<b>Net Revenue/(Expense)</b>	<b>(314,162)</b>		<b>(226,694)</b>			

\*All figures are unaudited

Notes:

1) Budget column is current budget which includes all year-to-date adjustments, if any.

City of Conway  
General Fund  
2014



Fund Balance Appropriations

<u>Ordinance</u>	<u>Date</u>	<u>Description</u>	<u>Amount</u>
O-14-02	1/14/14	Employee fitness center membership	16,238
O-14-13	1/28/14	Fire dept purchase of air compressor for breathing apparatuses	19,839
O-14-14	1/28/14	Additional MEMS subsidy	27,500
O-14-23	2/25/14	Purchase computers	25,548
O-14-25	3/18/14	Repair Planning Dept car	4,503
O-14-28	3/18/14	Purchase computers	107,359
O-14-41	5/13/14	Civil Service Commission expenses	8,751
			<u>\$ 209,738</u>

City of Conway  
 Balance Sheet - General Fund  
 For the month ended June 30, 2014



Cash - Operating	3,193,909
Cash - Reserve	1,000,000
Petty Cash	715
Taxes Receivable	2,500,000
Accounts Receivable	2,689,892
Due from Street	52,504
Fleet Inventory	15,539
Fuel Inventory	(3,817)
General Inventory	2,732
<b><i>Assets</i></b>	<b><u>9,451,475</u></b>
Accounts Payable	151,117
Insurance and Benefits Payable	32,308
Event Deposits	600
Due to Other Funds	21,551
Deferred Revenue	2,557,322
<b><i>Liabilities</i></b>	<b><u>2,762,898</u></b>
Fund Balance - Committed to cash flow	2,000,000
Fund Balance - Committed to reserve	1,000,000
Fund Balance - Unassigned	3,688,577
<b><i>Fund Balance</i></b>	<b><u>6,688,577</u></b>
<b><i>Total Liabilities &amp; Fund Balance</i></b>	<b><u>9,451,475</u></b>

\*All figures are unaudited

City of Conway  
 Monthly Financial Report - Street Fund  
 For the month ended June 30, 2014



	<u>Budget</u>	<u>Month Activity</u>	<u>Year to Date</u>	<u>Encumbered</u>	<u>(Over)/Under Budget</u>	<u>% Expend/Collect</u>
<b>Revenues</b>						
Ad Valorem Tax	1,450,000	313,573	515,634		934,366	36%
Payments in Lieu of Tax	15,000	-	-		15,000	0%
State Tax Turnback	3,402,296	293,838	1,729,972		1,672,324	51%
Severance Tax	250,000	36,086	157,084		92,916	63%
Sales Tax	245,000	18,639	111,077		133,923	45%
Sign Permits	500	-	240		260	48%
Engineering Fees	10,000	200	3,075		6,925	31%
Interest Income	3,500	1,546	8,601		(5,101)	246%
Miscellaneous Revenues	-	200	200		(200)	-
<b>Total Revenues</b>	<b>5,376,296</b>	<b>664,081</b>	<b>2,525,882</b>	<b>-</b>	<b>2,850,414</b>	<b>47%</b>
<b>Expenditures</b>						
Personnel Costs	2,137,888	184,495	951,061	-	1,186,827	44%
Other Operating Costs	<u>3,278,012</u>	<u>193,198</u>	<u>978,202</u>	<u>133,283</u>	<u>2,166,527</u>	<u>30%</u>
Total Operating Costs	5,415,900	377,693	1,929,263	133,283	3,353,354	36%
Capital Outlay	<u>289,000</u>	<u>3,250</u>	<u>104,338</u>	<u>-</u>	<u>184,662</u>	<u>36%</u>
<b>Total Expenditures</b>	<b>5,704,900</b>	<b>380,943</b>	<b>2,033,601</b>	<b>133,283</b>	<b>3,538,016</b>	<b>36%</b>
<b>Net Revenue/(Expense)</b>	<b>(328,604)</b>		<b>492,281</b>			

\*All figures are unaudited

Notes:

- 1) Budget column is current budget which includes all year-to-date adjustments, if any.

City of Conway

Street Fund

2014

Fund Balance Appropriations



<u>Ordinance</u>	<u>Date</u>	<u>Description</u>	<u>Amount</u>
O-14-24	3/18/14	New part-time traffic data collector position	3,604

City of Conway  
Balance Sheet - Street Fund  
For the month ended June 30, 2014



Cash - Operating	2,479,013
Taxes Receivable	35,000
Accounts Receivable	1,613,174
Due from Other Funds	6,451
<b><i>Assets</i></b>	<b><u>4,133,668</u></b>
Accounts Payable	46,077
Due to General	52,504
Deferred Revenue	1,264,754
<b><i>Liabilities</i></b>	<b><u>1,363,335</u></b>
<b><i>Fund Balance</i></b>	<b>2,770,333</b>
<b><i>Total Liabilities &amp; Fund Balance</i></b>	<b><u>4,133,668</u></b>

\*All figures are unaudited

City of Conway  
 Monthly Financial Report - Sanitation  
 For the month ended June 30, 2014



	<u>Budget</u>	<u>Month</u> <u>Activity</u>	<u>Year to</u> <u>Date</u>	<u>Encumbered</u>	<u>(Over)/Under</u> <u>Budget</u>	<u>%</u> <u>Expend/Collect</u>
<b>Revenues</b>						
Sanitation Fees	9,120,000	759,799	4,479,504		4,640,496	49%
Proceeds - Recycled Materials	300,000	63,230	185,554		114,446	62%
Landfill Fees - General	240,000	22,350	121,011		118,989	50%
Insurance Proceeds	-	1,643	1,643		(1,643)	-
Interest Income	55,000	4,294	24,279		30,721	44%
Proceeds from Sale of Assets	-	-	495		(495)	-
Gain/Loss Disposal of Asset	-	-	(1,082)		1,082	-
Miscellaneous Revenues	-	72	762		(762)	-
<b>Total Revenues</b>	<b>9,715,000</b>	<b>851,389</b>	<b>4,812,168</b>	<b>-</b>	<b>4,902,832</b>	<b>50%</b>
<b>Expenditures</b>						
Personnel Costs	3,895,858	267,446	1,774,694	-	2,121,164	46%
Other Operating Costs	3,369,142	231,556	1,524,536	112,464	1,732,142	45%
Total Operating Costs	7,265,000	499,002	3,299,230	112,464	3,853,306	45%
Capital Outlay	2,712,843	-	9,500	451,981	2,251,362	0.4%
<b>Total Expenditures</b>	<b>9,977,843</b>	<b>499,002</b>	<b>3,308,730</b>	<b>564,445</b>	<b>6,104,668</b>	<b>33%</b>
<b>Net Revenue/(Expense)</b>	<b>(262,843)</b>		<b>1,503,438</b>			

\*All figures are unaudited

Notes:

- 1) Budget column is current budget which includes all year-to-date adjustments, if any.
- 2) Capital outlay is shown here for budgeting purposes, but only depreciation expense will be recorded at year end.



City of Conway  
 Balance Sheet - Sanitation  
 For the month ended June 30, 2014



Cash - Operating	2,687,932
Petty Cash	200
Post Closure Cash Account	4,984,849
Due from Other Funds	14,365
General Inventory	2,122
Land & Buildings	2,914,029
Infrastructure	1,236,034
Machinery and Equipment	6,398,752
Vehicles	36,514
Computer Equip & Software	4,792
<b><i>Assets</i></b>	<b><u>18,279,590</u></b>
Accounts Payable	35,634
Salaries Payable	336,164
Net Pension Obligation	855,700
Accrued Interest Payable	32,255
2010 Recycling Note - US Bank	809,873
Landfill Close/Post Close	4,386,590
<b><i>Liabilities</i></b>	<b><u>6,456,215</u></b>
<b><i>Net Assets</i></b>	<b><u>11,823,375</u></b>
<b><i>Total Liabilities and Net Assets</i></b>	<b><u>18,279,590</u></b>

**\*All figures are unaudited**

Note: Capital assets shown at book value (cost less accumulated depreciation).